

QUANTUM^X MX840

Universal amplifier



Special features

- Universal amplifier with 8 individually adjustable inputs
- Sampling rate: up to 19.2 kHz per channel
- 24-bit A/D converter per channel for synchronous, parallel measurements
- Filter: Bessel, Butterworth
0.01 Hz up to 3.2 kHz (-3 dB)
- Supply voltage: 10 ... 30 VDC
- All inputs electrically isolated
- Supply voltage for active transducers: 5...24 VDC adjustable for each channel

Block diagram

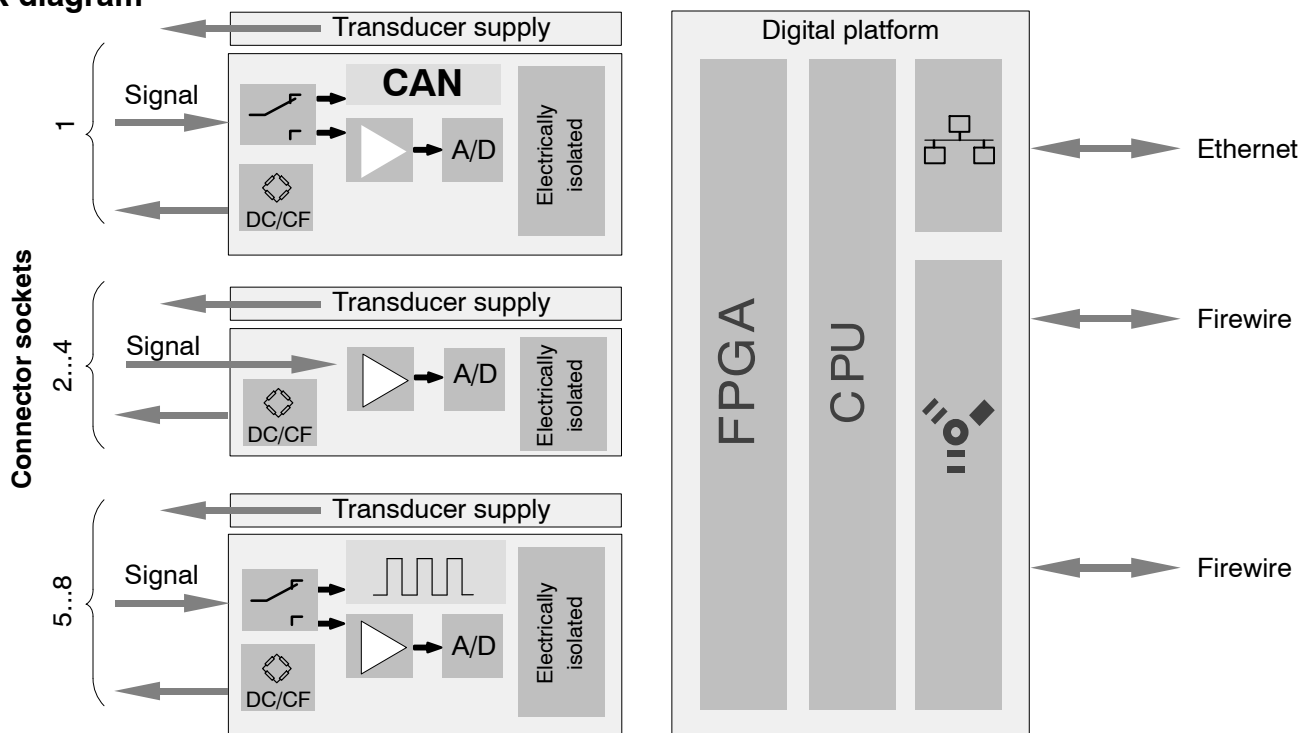

Specifications

General specifications, valid for all measuring ranges		
Supply voltage range	V (DC)	10 ... 30, 24 V nominal (rated) voltage
Supply voltage interruption		max. 5 ms at 24 V
Power consumption without adjustable transducer excitation	W	< 10
Power consumption with adjustable transducer excitation	W	< 13
Adjustable supply voltage for all transducers Adjustable voltage Maximum output power	V (DC) W	5 ... 24; adjustable for each channel 0.7 each channel / a total of 2
Transducer identification max. distance of the TEDS module	m	100
Transducer connector		D-SUB-15HD
Protection class (up to 2000 m height, degree of contamination 2)		III per EN 61326
EMC requirements		per EN 61326
Maximum input voltage at transducer socket to ground (PIN 6) PIN 1, 2, 3, 4, 5, 7, 8, 10, 13 PIN 14	V V	5.5 (no transients) 60 (no transients)
Nominal (rated) temperature range	°C [°F]	-20 ... +60 [-4 ... +140]
Operating temperature range	°C [°F]	-20 ... +65 [-4 ... +149]
Storage temperature range	°C [°F]	-40 ... +75 [-40 ... +167]
Rel. humidity at 31 °C	%	80 (non condensing) lin. reduction to 50 % at 40 °C
Dimensions (H x W x D)	mm	44 x 174 x 119 (without case protection 1-CASEPROT) 52.5 x 200 x 122 (with case protection 1-CASEPROT)
Degree of protection		IP20 per EN 60529
Weight	g	980

5 mV/V AC strain gage full bridge with 1 V _{eff} or 2.5 V _{eff} excitation		
Accuracy class		0.05
Carrier frequency (sine)	Hz	4801.25 ± 0.6
Bridge excitation voltage	V _{eff}	1 and 2.5 (± 5 %)
Transducers that can be connected		strain gage full bridges
Permissible cable length between MX840 and transducer	m	100
Measuring ranges at 2.5 V excitation at 1 V excitation	mV/V mV/V	± 5 ± 10
Measurement frequency range (-3 dB)	kHz	0 ... 1.6
Transducer impedance at 2.5 V excitation at 1 V excitation	Ω Ω	300 ... 1000 80 ... 1000
Noise at 25 °C and 2.5 V excitation with filter 1 Hz Bessel with filter 10 Hz Bessel with filter 100 Hz Bessel with filter 1 kHz Bessel	μV/V _{pp} μV/V _{pp} μV/V _{pp} μV/V _{pp}	< 0.2 < 0.5 < 1 < 4
Linearity error	%	< 0.02 of full scale
Zero drift (2.5 V _{eff} excitation)	% / 10 K	0.02 of full scale
Full-scale drift (2.5 V _{eff} excitation)	% / 10 K	< 0.05 of measurement value

Specifications (Continued)

100 mV/V AC inductive full bridge with 1 V _{eff} or 2.5 V _{eff} excitation		
Accuracy class		0.05
Carrier frequency (sine)	Hz	4801.25 ± 0.6
Bridge excitation voltage	V _{eff}	1 and 2.5 (± 5 %)
Transducers that can be connected		inductive full bridges
Permissible cable length between MX840 and transducer	m	100
Measuring ranges at 2.5 V excitation at 1 V excitation	mV/V mV/V	± 100 ± 300
Measurement frequency range (-3 dB)	kHz	0 ... 1.6
Transducer impedance at 2.5 V excitation at 1 V excitation	Ω Ω	300 ... 1000 80 ... 1000
Noise at 25 °C and 2.5 V excitation with filter 1 Hz Bessel with filter 10 Hz Bessel with filter 100 Hz Bessel with filter 1 kHz Bessel	μV/V _{pp} μV/V _{pp} μV/V _{pp} μV/V _{pp}	< 3 < 5 < 15 < 50
Linearity error	%	< 0.02 of full scale
Zero drift (2.5 V _{eff} excitation)	% / 10 K	< 0.02 of full scale
Full-scale drift (2.5 V _{eff} excitation)	% / 10 K	< 0.05 of measurement value

100 mV/V AC inductive half bridge with 1 V _{eff} or 2.5 V _{eff} excitation		
Accuracy class		0,1
Carrier frequency (sine)	Hz	4801.25 ± 0.6
Bridge excitation voltage	V _{eff}	1 and 2.5 (± 5 %)
Transducers that can be connected		inductive half bridges
Permissible cable length between MX840 and transducer	m	100
Measuring ranges at 2.5 V excitation at 1 V excitation	mV/V mV/V	± 100 ± 300
Measurement frequency range (-3 dB)	kHz	0 ... 1.6
Transducer impedance at 2.5 V excitation at 1 V excitation	Ω Ω	300 ... 1000 80 ... 1000
Noise at 25 °C and 2.5 V excitation with filter 1 Hz Bessel with filter 10 Hz Bessel with filter 100 Hz Bessel with filter 1 kHz Bessel	μV/V _{pp} μV/V _{pp} μV/V _{pp} μV/V _{pp}	< 3 < 5 < 15 < 50
Linearity error	%	< 0.02 of full scale
Zero drift (2.5 V _{eff} excitation)	% / 10 K	< 0.1 of full scale
Full-scale drift (2.5 V _{eff} excitation)	% / 10 K	< 0.1 of measurement value

Specifications (Continued)

100 mV/V DC piezoresistive strain gage full bridge with 2.5 V DC excitation		
Accuracy class		0.05
Bridge excitation voltage	V (DC)	2.5
Transducers that can be connected		piezoresistive strain gage full bridges
Permissible cable length between MX840 and transducer	m	100
Measuring range	mV/V	± 100
Measurement frequency range (-3 dB)	kHz	0 ... 3.2
Transducer impedance	Ω	300 ... 1000
Noise at 25 °C		
with filter 1 Hz Bessel	μV/V _{pp}	< 4
with filter 10 Hz Bessel	μV/V _{pp}	< 6
with filter 100 Hz Bessel	μV/V _{pp}	< 15
with filter 1 kHz Bessel	μV/V _{pp}	< 80
Linearity error	%	< 0.02 of full scale
Zero drift (2.5 V excitation)	% / 10 K	< 0.02 of full scale
Full-scale drift (2.5 V excitation)	% / 10 K	< 0.05 of measurement value

1000 mV/V AC inductive full bridge with 1 V _{eff} excitation		
Accuracy class		0,05
Carrier frequency (sine)	Hz	4801.25 ± 0.6
Bridge excitation voltage	V _{eff}	1 (± 5 %)
Transducers that can be connected		inductive full bridges
Permissible cable length between MX840 and transducer	m	100
Measuring range	mV/V	± 1000
Measurement frequency range (-3 dB)	kHz	0 ... 1.6
Transducer impedance	Ω	80 ... 1000
Noise at 25 °C		
with filter 1 Hz Bessel	μV/V _{pp}	< 40
with filter 10 Hz Bessel	μV/V _{pp}	< 100
with filter 100 Hz Bessel	μV/V _{pp}	< 500
with filter 1 kHz Bessel	μV/V _{pp}	< 1200
Linearity error	%	< 0.02 of full scale
Zero drift (1 V _{eff} excitation)	% / 10 K	< 0.02 of full scale
Full-scale drift (1 V _{eff} excitation)	% / 10 K	< 0.1 of measurement value

Specifications (Continued)

LVDT		
Accuracy class		0.1
Carrier frequency (sine)	Hz	4801.25 ± 0.6
Bridge excitation voltage	V_{eff}	1 (± 5 %)
Transducers that can be connected		LVDT
Permissible cable length between MX840 and transducer	m	100
Measuring range	mV/V	± 3000
Measurement frequency range (-3 dB)	kHz	0 ... 1.6
Transducer impedance	mH	4 ... 33
Noise at 25 °C		
with filter 1 Hz Bessel	$\mu\text{V}/V_{\text{pp}}$	< 40
with filter 10 Hz Bessel	$\mu\text{V}/V_{\text{pp}}$	< 100
with filter 100 Hz Bessel	$\mu\text{V}/V_{\text{pp}}$	< 500
with filter 1 kHz Bessel	$\mu\text{V}/V_{\text{pp}}$	< 1200
Linearity error	%	< 0.02 of full scale
Zero drift (1 V_{eff} excitation)	% / 10 K	< 0.1 of full scale
Full-scale drift (1 V_{eff} excitation)	% / 10 K	< 0.1 of measurement value

1000 mV/V DC piezoresistive strain gage full bridge with 2.5 V excitation		
Accuracy class		0.05
Bridge excitation voltage	V (DC)	2.5
Transducers that can be connected		piezoresistive strain gage full bridges
Permissible cable length between MX840 and transducer	m	100
Measuring range	mV/V	± 1000
Measurement frequency range (-3 dB)	kHz	0 ... 3.2
Transducer impedance	Ω	300 ... 1000
Noise at 25 °C		
with filter 1 Hz Bessel	$\mu\text{V}/V_{\text{pp}}$	< 40
with filter 10 Hz Bessel	$\mu\text{V}/V_{\text{pp}}$	< 100
with filter 100 Hz Bessel	$\mu\text{V}/V_{\text{pp}}$	< 200
with filter 1 kHz Bessel	$\mu\text{V}/V_{\text{pp}}$	< 700
Linearity error	%	< 0.02 of full scale
Zero drift (1 V excitation)	% / 10 K	< 0.02 of full scale
Full-scale drift (1 V excitation)	% / 10 K	< 0.1 of measurement value

Specifications (Continued)

Potentiometric transducer		
Accuracy class		0.1
Bridge excitation voltage	V (DC)	2.5
Transducers that can be connected		potentiometric transducers
Permissible cable length between MX840 and transducer	m	100
Measuring range	mV/V	± 1000
Measurement frequency range (-3 dB)	kHz	0 ... 3.2
Transducer impedance	kΩ	5
Noise at 25 °C		
with filter 1 Hz Bessel	μV/V _{pp}	< 40
with filter 10 Hz Bessel	μV/V _{pp}	< 100
with filter 100 Hz Bessel	μV/V _{pp}	< 200
with filter 1 kHz Bessel	μV/V _{pp}	< 700
Linearity error	%	< 0.02 of full scale
Zero drift (1 V excitation)	% / 10 K	< 0.1 of full scale
Full-scale drift (1 V excitation)	% / 10 K	< 0.1 of measurement value

10 V DC voltage		
Accuracy class		0.05
Transducers that can be connected		voltage generator ± 10 V
Permissible cable length between MX840 and transducer	m	100
Measuring range	V	± 10
Measurement frequency range (-3 dB)	kHz	0 ... 3.2
Internal resistance of the voltage source	Ω	< 500
Internal impedance	MΩ	typ. 1
Noise at 25 °C		
with filter 1 Hz Bessel	μV _{pp}	< 150
with filter 10 Hz Bessel	μV _{pp}	< 300
with filter 100 Hz Bessel	μV _{pp}	< 600
with filter 1 kHz Bessel	μV _{pp}	< 3000
Linearity error	%	< 0.02 of full scale
Common-mode rejection		
with DC common mode	dB	> 100
with 50 Hz common mode	dB	typ. 75
Maximum common-mode voltage (to housing and supply ground)	V	± 60
Zero drift	% / 10 K	< 0.02 of full scale
Full-scale drift	% / 10 K	< 0.1 of measurement value

Specifications (Continued)

60 V DC voltage		
Accuracy class		0.05
Transducers that can be connected		voltage generator ± 60 V
Permissible cable length between MX840 and transducer	m	100
Measuring range	V	± 60
Measurement frequency range (-3 dB)	kHz	0 ... 3.2
Internal resistance of the voltage source	Ω	< 500
Input impedance	M Ω	typ. 1
Noise at 25 °C		
with filter 1Hz Bessel	μV_{pp}	< 150
with filter 10Hz Bessel	μV_{pp}	< 300
with filter 100Hz Bessel	μV_{pp}	< 600
with filter 1kHz Bessel	μV_{pp}	< 3000
Linearity error	%	< 0.02 of full scale
Common-mode rejection		
with DC common mode	dB	> 100
with 50 Hz common mode	dB	typ. 75
Maximum common-mode voltage (to housing and supply ground)	V	± 60
Zero drift	% / 10 K	< 0.02 of full scale
Full-scale drift	% / 10 K	< 0.05 of measurement value

100 mV DC voltage		
Accuracy class		0.05
Transducers that can be connected		voltage generator
Permissible cable length between MX840 and transducer	m	100
Measuring range	mV	± 300
Measurement frequency range (-3 dB)	kHz	0 ... 3.2
Input impedance	M Ω	> 20
Noise at 25 °C		
with filter 1 Hz Bessel	μV_{pp}	< 5
with filter 10 Hz Bessel	μV_{pp}	< 100
with filter 100 Hz Bessel	μV_{pp}	< 1000
with filter 1 kHz Bessel	μV_{pp}	< 1500
Linearity error	%	< 0.03 of full scale
Common-mode rejection		
with DC common mode	dB	> 90
with 50 Hz common mode	dB	typ. 75
Maximum common-mode voltage (to housing and supply ground)	V	± 30
Zero drift	% / 10 K	< 0.1 of full scale
Full-scale drift	% / 10 K	< 0.1 of measurement value

Specifications (Continued)

20 mA DC current		
Accuracy class		0.05
Transducers that can be connected		transducers with 4 ... 20 mA current output
Permissible cable length between MX840 and transducer	m	100
Measuring range	mA	±30
Measurement frequency range (-3 dB)	kHz	0 ... 3.2
Measurement resistance value	Ω	typ. 10
Noise at 25 °C with filter 1 Hz Bessel with filter 10 Hz Bessel with filter 100 Hz Bessel with filter 1 kHz Bessel	μA _{pp} μA _{pp} μA _{pp} μA _{pp}	< 1 < 1.5 < 15 < 40
Linearity error	%	< 0.02 of full scale
Common-mode rejection with DC common mode with 50 Hz common mode	dB dB	> 100 typ. 75
Maximum common-mode voltage (to housing and supply ground)	V	±30
Zero drift	% / 10 K	< 0.05 of full scale
Full-scale drift	% / 10 K	< 0.1 of measurement value

Resistance thermometer		
Transducers that can be connected		resistance thermometers
Permissible cable length between MX840 and transducer	m	100
Measuring ranges		PT100 PT1000
Linearization range	°C [°F]	-200 ... +848 [-328 ... +1558.4]
Measurement frequency range (-3 dB)	kHz	0 ... 3.2
Noise at 25 °C with filter 1 Hz Bessel with filter 10 Hz Bessel with filter 100 Hz Bessel with filter 1 kHz Bessel	K _{pp} K _{pp} K _{pp} K _{pp}	< 0.1 < 0.2 < 0.5 < 1.5
Linearity error	K	< ±0.3
Zero drift with PT100 with PT1000	K / 10 K K / 10 K	<0.2 <0.1
Full-scale drift with PT100 with PT1000	K / 10 K K / 10 K	<0.5 <1

Specifications (Continued)

Thermocouples		
Transducers that can be connected		Thermocouples
Permissible cable length between MX840 and transducer	m	100
Measuring range	mV	± 100
Linearization ranges		
Type K	°C [°F]	-270 ... +1372 [-454 ... +2501.6]
Type J	°C [°F]	-210 ... +1200 [-346 ... +2192]
Type S	°C [°F]	-50 ... +1768 [-58 ... +3214.4]
Type T	°C [°F]	-270 ... +400 [-454 ... +752]
Type R	°C [°F]	-50 ... +1768 [-328 ... +1652]
Type E	°C [°F]	-200 ... +900 [-328 ... +1652]
Type N	°C [°F]	-270 ... +1300 [-454 ... +2372]
Type B	°C [°F]	100 ... +1820 [+212 ... +3308]
Measurement frequency range (-3 dB)	kHz	0 ... 3.2
Noise at 25 °C and Type K		
with Filter 1 Hz Bessel	K_{pp}	0.05
with Filter 10 Hz Bessel	K_{pp}	0.1
with Filter 100 Hz Bessel	K_{pp}	0.5
with Filter 1 kHz Bessel	K_{pp}	1
Zero error		
Type K, J, T, E	K	< ± 0.3
Type N, R, S	K	< ± 3
Type B	K	< ± 30
Linearity error		
Type K, J, T, E	K	< ± 0.3
Type N, R, S	K	< ± 3
Type B	K	< ± 30
Max. error of the cold junction	K	< ± 0.5
Total error limit		
Type K, J, T, E	K	± 1
Type N, R, S	K	± 6.5
Type B	K	± 60

Frequency or pulse counting (connections 5 ... 8)		
Accuracy class		0.01
Transducers that can be connected		Torque transducers, Frequency signal sources (square and sine), incremental encoder
Permissible cable length between MX840 and transducer	m	50
Signals		
F1 (±)		Frequency or pulse signal
F2 (±)		Direction of rotation signal shifted by ± 90° to F1
Zero index (±)		Zero position signal
Input level with differential operation		
Low level		Differential inputs (RS422): Signal (+) < Signal (-) -200 mV
High level		Differential inputs (RS422): Signal (+) > Signal (-) +200 mV
Input level with unipolar operation		
Low level	V	< 1.5
High level	V	> 3.5
Measuring ranges		
Frequency		0.1 Hz ... 1000 kHz
Pulse counting	pulses/s	0 ... 1000000
Input impedance	kΩ	typ. 10

Specifications (Continued)

CAN (connection 1)						
Supported protocols		CAN 2.0A, CAN 2.0B				
Number of CAN-ports		1				
Bus link		two wire, according to ISO11898				
Baud rates and permissible cable lengths	kBit/s m	1000, 25,	500, 100,	250, 250,	125, 500,	100 600
Sampling rate	signals/s	max. 10000				
CAN channels		≤ 128				
CAN signal types		standard, mode-dependent, mode-signal				

Amplitude responses of the adjustable filters

MX840 low-pass filter data (Filter order = 4)

Type	-1dB (Hz)	-3dB (Hz)	-20dB (Hz)	Phase delay (ms)	Rise time (ms)	Overshoot (%)	Rate [Hz]
Bessel	2000	3210	8100	0,15	0,1	1,5	19200
	1000	1630	4050	0,24	0,2	1,4	19200
	1000	1640	5150	0,21	0,2	0,7	9600
	500	820	2120	0,4	0,43	1,4	9600
	200	335	860	1	1,04	1	9600
	100	167	430	2	2,1	0,8	9600
	50	83	215	4	4,28	0,8	9600
	20	33,7	85	10	10,6	0,8	9600
	10	16,5	42	20	21,3	0,8	9600
	5	8,4	21	40	41,6	0,8	2400
	2	3,4	8,5	99	104	0,8	2400
	1	1,6	4,2	200	214	0,8	2400
	0,5	0,83	2,1	400	420	0,8	300
	0,2	0,34	0,85	1000	1060	0,8	300
	0,1	0,17	0,43	2000	2130	0,8	300
	0,05	0,084	0,21	3940	4200	0,8	20
	0,02	0,033	0,085	10000	10600	0,8	20
0,01	0,017	0,042	20100	21300	0,8	20	
Butterworth	2000	2360	4331	0,2	0,15	11	19200
	1000	1178	2100	0,38	0,3	11	19200
	1000	1168	2140	0,32	0,32	11	9600
	500	586	1050	0,66	0,66	11	9600
	200	235	420	1,7	1,6	11	9600
	100	118	210	3,46	3,2	11	9600
	50	49	105	6,98	6,6	11	9600
	20	24	42	17,3	16	11	9600
	10	12	21	34,9	32	11	9600
	5	5,95	10,5	69	66	11	2400
	2	2,37	4,24	173	160	11	2400
	1	1,26	2,1	347	320	11	2400
	0,5	0,59	1,05	701	660	11	300
	0,2	0,236	0,421	1760	1600	11	300
	0,1	0,118	0,21	3510	3200	11	300
	0,05	0,059	0,105	6950	6600	11	20
	0,02	0,0235	0,042	17500	16000	11	20
0,01	0,012	0,021	34600	32000	11	20	

Amplitude response of MX840 Butterworth filter

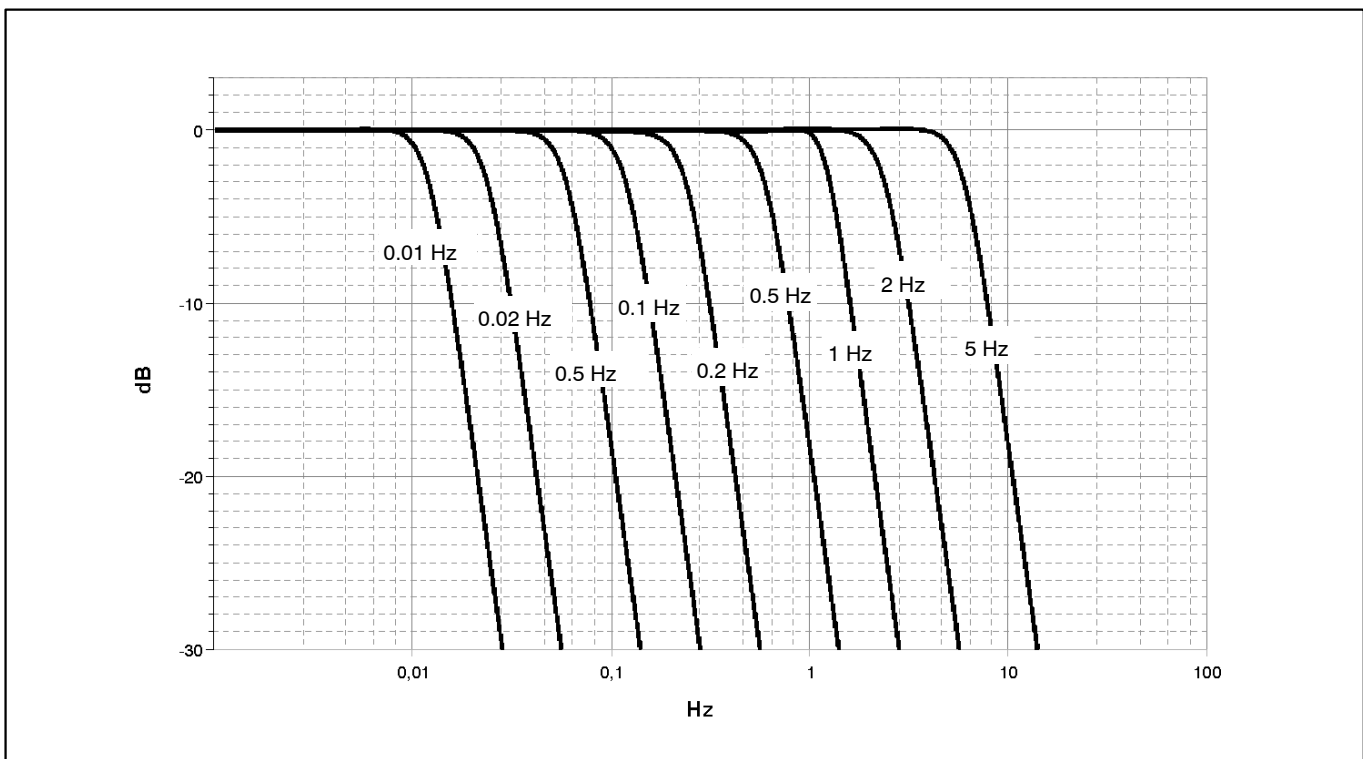
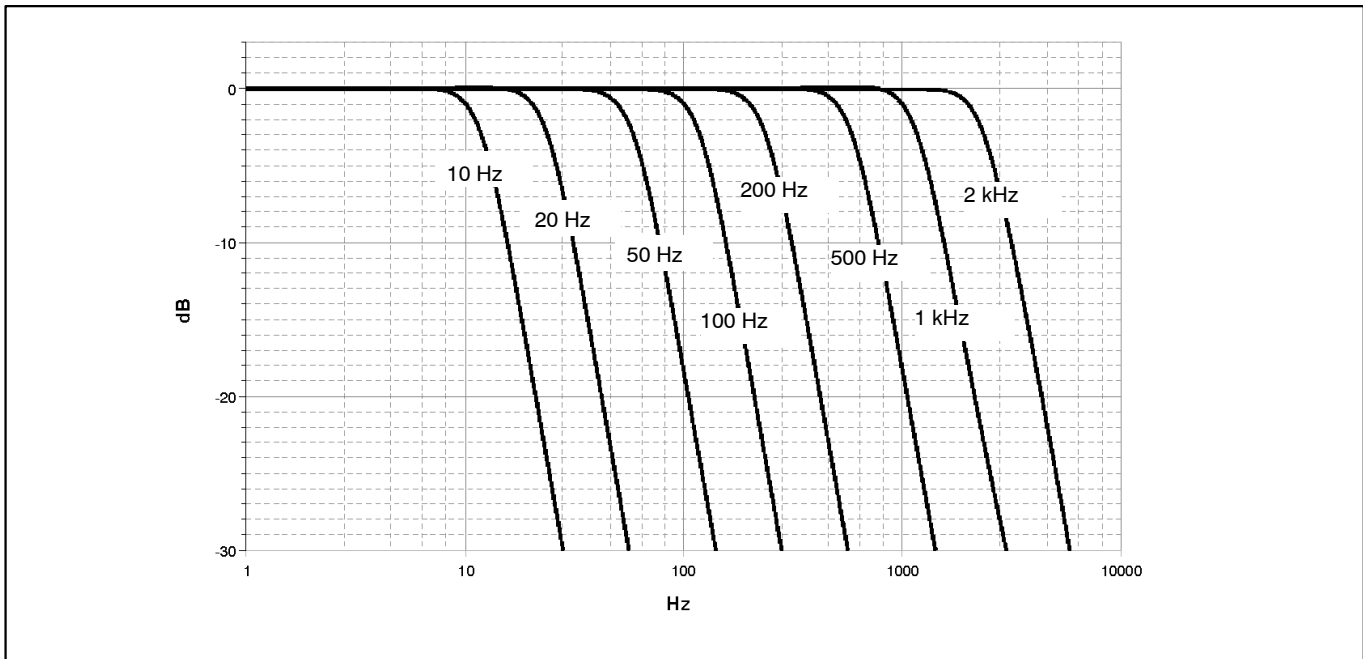

Amplitude response of MX840 Bessel filter

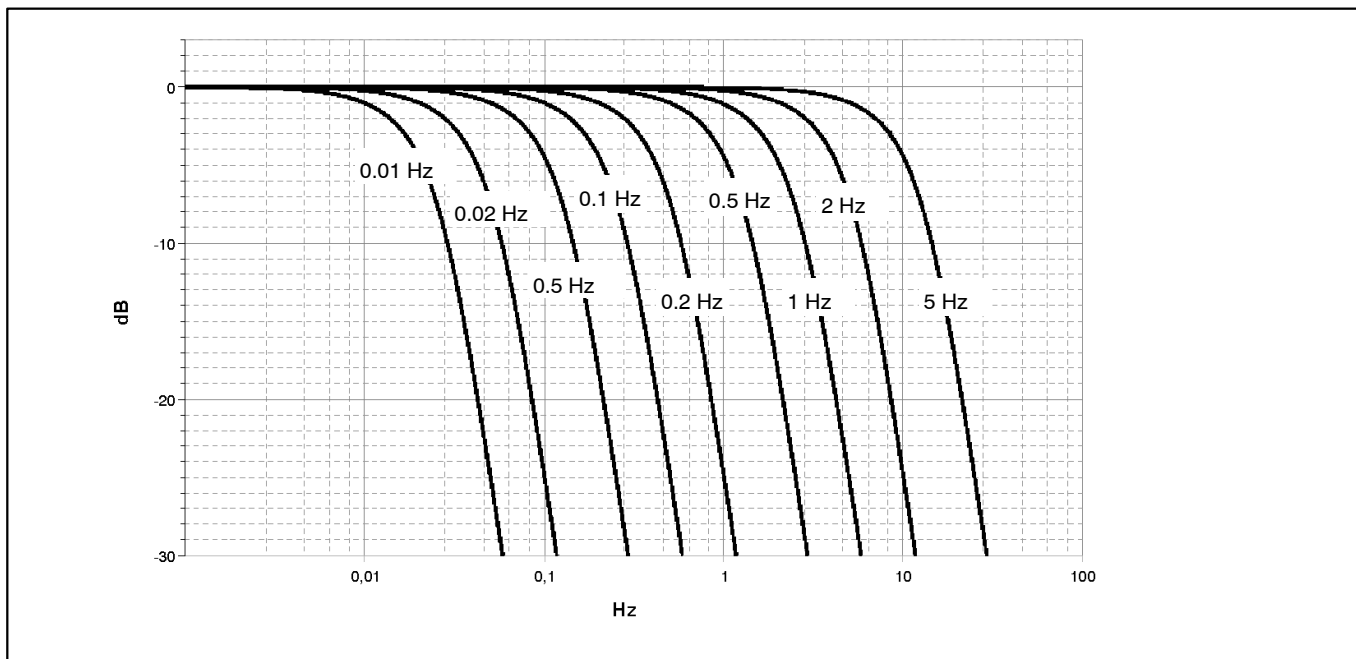
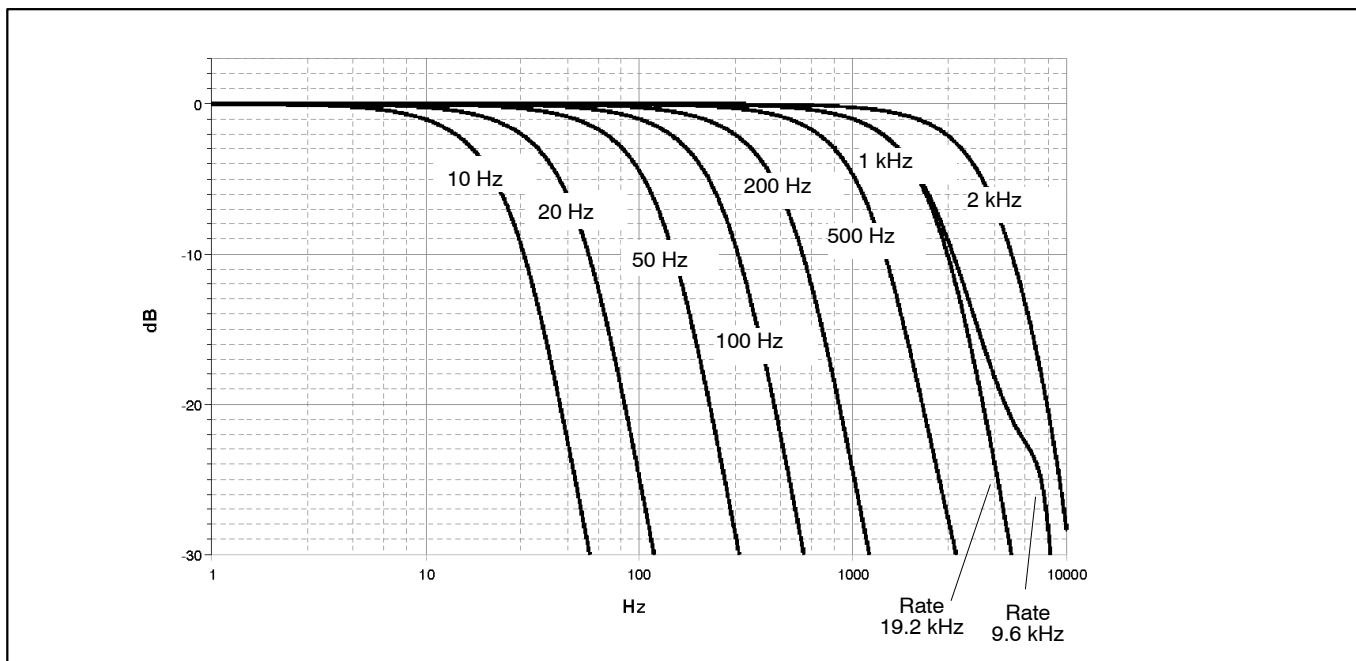

Accessories, to be ordered separately

1-Kab271-3 mains connection cable

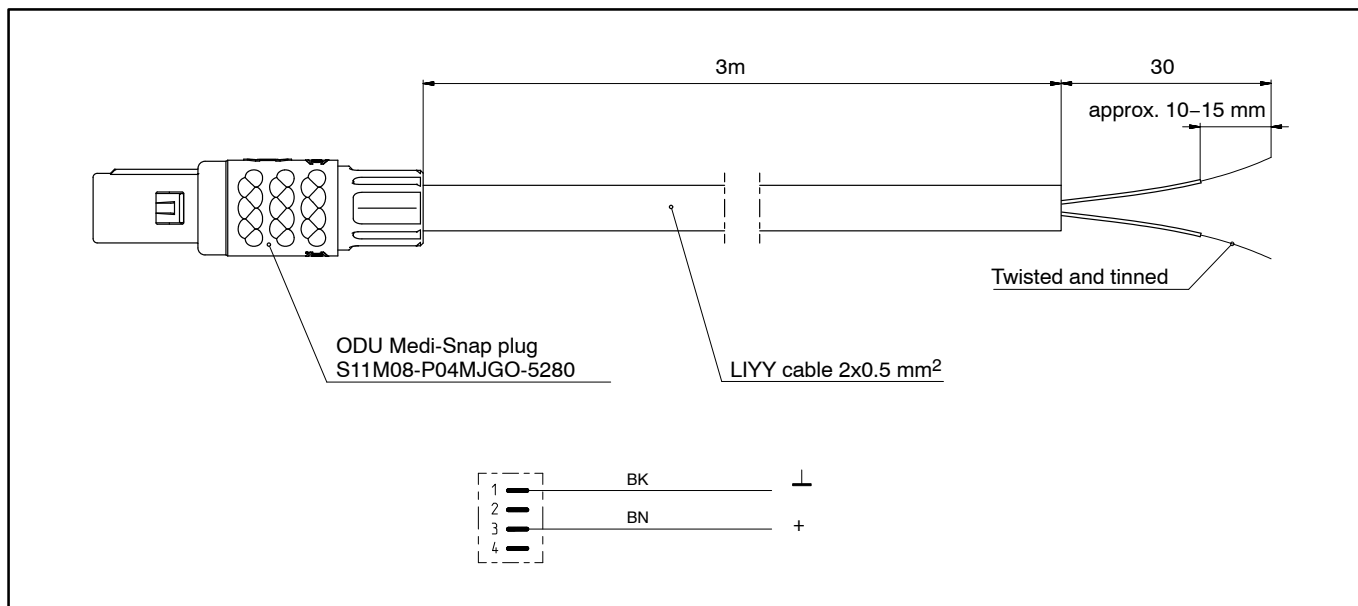

1-Kab416 transducer adapter cable for bridge connection

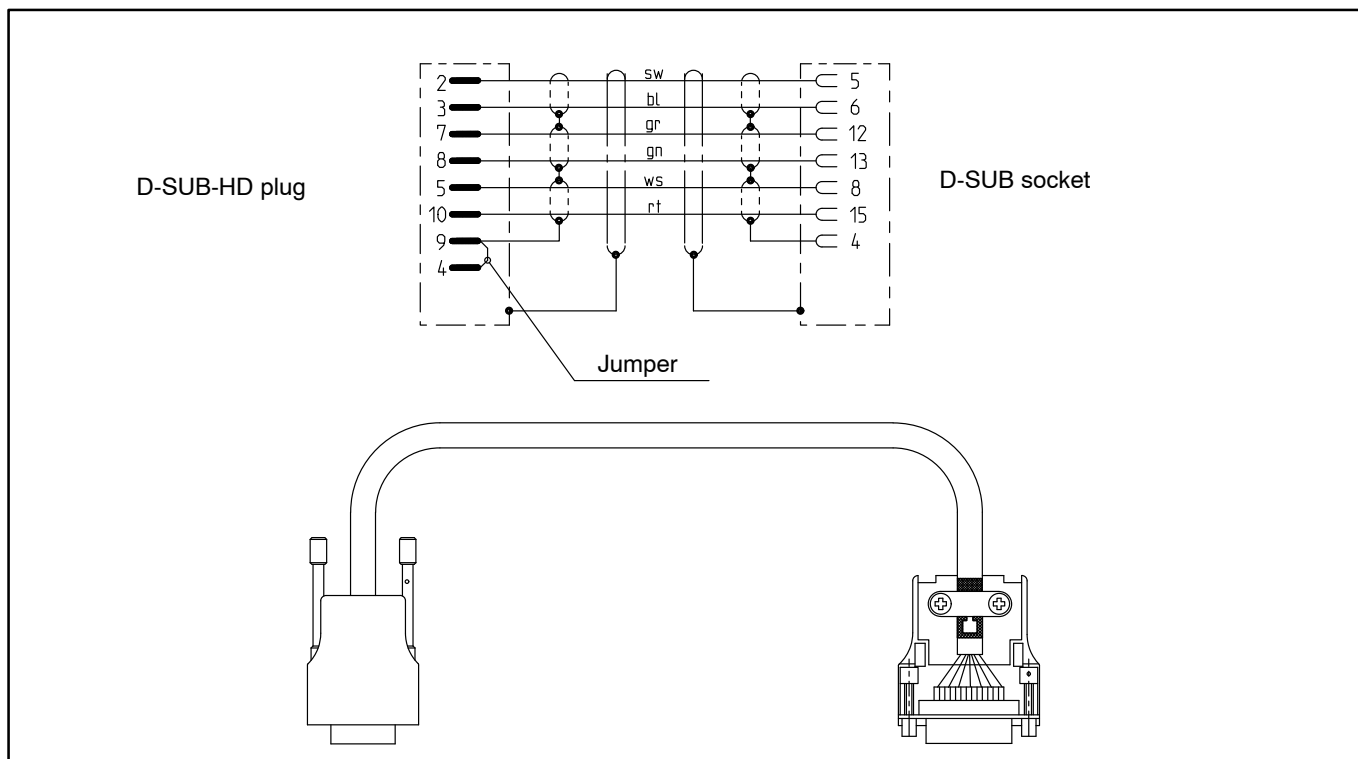

1-Kab418 (CAN) adapter cable

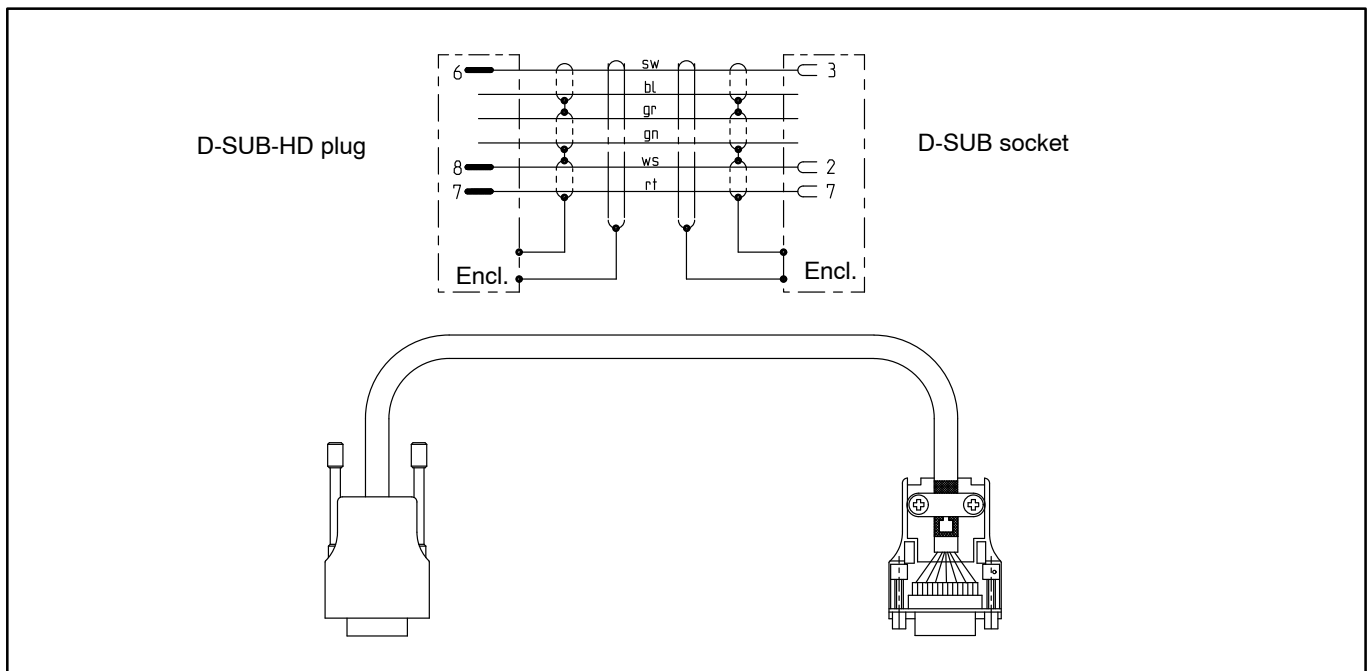

Accessories,

1-KAB271-3	Voltage supply cable for MX amplifiers, ODU – free ends.
1-KAB269-2	Firewire connection cable for connecting MX amplifiers. Length about 2 m
1-KAB269-0.2	Firewire connection cable for connecting MX amplifiers. Length about 20 cm
1-KAB416	DSUB15-HD to DSUB adapter cable for connection of transducers to MX amplifiers; prepared for other HBM amplifiers. Length about 30 cm
1-KAB418	DSUB15-HD to DSUB socket adapter cable for connection of CAN devices to MX840. Length about 30 cm
1-CASECLIP	Set including 2 case clips for fast mounting of 2 MX amplifiers.
1-NTX001	Plug-in power supply for MX amplifiers
1-SUBHD15-MALE	DSUB15-HD transducer plug kit for MX amplifiers. Kit includes 4kBit 1-wire TEDS chip
1-THERMO-MXBOARD	Board with temperature comparison element and 4kBit 1-wire TEDS chip for DSUB15-HD transducer plug.

Specifications Power pack NX001

NTX001		
Nominal input voltage	VAC	90 – 264
Stand-by power consumption at 230 V	W	0.5
Nominal load		
U_A	V	24
I_A	A	1.25
Static output characteristics		
U_A	V	$24 \pm 4\%$
I_A	A	0 – 1.25
U_{Br} (Output voltage ripple)	mV _{SS}	≤ 120
Current limiting, typically from	A	1.6
Primary – secondary separation		galvanically, by optocoupler and converter
Creep distance and clearance	mm	≥ 8
High-voltage test	kV	≥ 4
Ambient temperature range	°C [°F]	0... +40 [+32 ... +104]
Storage temperatur	°C [°F]	-40 ... +70 [-40 ... +158]

Änderungen vorbehalten.

Alle Angaben beschreiben unsere Produkte in allgemeiner Form. Sie stellen keine Beschaffenheits- oder Haltbarkeitsgarantie im Sinne des §443 BGB dar und begründen keine Haftung.

B2358-1.1 en

Hottinger Baldwin Messtechnik GmbH

Postfach 10 01 51, D-64201 Darmstadt
Im Tiefen See 45, D-64293 Darmstadt
Tel.: 061 51/ 8 03-0; Fax: 061 51/ 8039100
E-mail: support@hbm.com www.hbm.com



measurement with confidence