



Briiel & Kjær Vibro



VIBROCONTROL-6000

Dependable Safety Monitoring

Safety Monitoring with VIBROCONTROL 6000



A modern processing plant employs expensive, sophisticated and sometimes high-speed machines. Every production manager knows the responsibility there is trying to maintain optimum production and product quality in a modern process plant. A high level of availability of the machines is often required, especially in the case of a plant where the production process is serial in nature, and a stoppage in one part of the plant may mean that the entire process must be stopped.

Situational problems

Regular measurements on machines using a portable vibration measuring instrument may be normally adequate for protecting sub-critical machines, or machines that are redundant, against damage that may result in the machine having to be stopped. However in the case of machines that are critical and are not redundant, high-speed machines or machines that take a long time and are expensive to repair, such a preventive measure is not sufficient. This strategy only reveals the machine condition during measurement and is no guarantee that the machine will continue to operate without developing a fault until the next measurement is done.

In a plant where machines critical to the continuous operation of the production process are unprotected, there is an ever-present danger that a machine or machine group may develop a fault at any time.

Depending on the seriousness of the fault and how quickly it will progress, the production process may have to be reduced to below optimum to prevent the machine suffering further damage or may perhaps even have to be stopped completely.

The consequences

Such a production stoppage can be extremely costly, may also jeopardise valuable contracts with the plant's customer and inevitably places extraordinary pressure on the maintenance manager to get the machine operating once more. If the damage is serious it may even call for spare parts that are not immediately available or, in a worst case scenario, replacement of the entire machine.

The only way to guarantee safety and protection for your valuable machinery and plant, minimise the amount of damage to the machine and thereby also provide protection of your capital investment is to implement a continuous on-line safety and protective monitoring system.

To be efficient and reliable any safety monitoring system

- Is categorised as part of the emergency shutdown system.
- Must prevent catastrophic machine failure.

- Must protect personnel, the environment and equipment from direct and secondary damage by
 - bringing production to a safe status after an unpredictable dangerous event and
 - maintaining this status until instructed.
- Must immediately identify any sudden critical deviation from a normal condition by
 - acquiring vital information at high speed,
 - performing continuous measurements in virtual real time and
 - continuously comparing these measurements with absolute predefined limit values.
- May speed up procedures by which the plant can be returned to normal operation.
- Must operated reliably by possessing a strategy to identify and manage faults within the monitoring system itself and finally
- Must minimise the eventuality of false alarms and unnecessary action

The solution

The VIBROCONTROL 6000 safety monitoring system has been designed specifically for this purpose. When a fault occurs the speed at which it can react to raise alarms or shut down the machine is your guarantee that the damage will be limited and consequential, or spin-off, damage to other machines can be prevented. The amount of damage the machine may suffer and the time taken to bring production back to normal can be extensively limited.

Your benefit

– The optimum modular safety monitoring system

Benefits of modularity:

- Independently operating monitoring modules each with up to 12 input channels
- Potential-free relays with logic-linking for alarming and event signalling
- Galvanic separation of DC outputs (current and voltage)
- Fail-safe operation for maximum machine protection
- AC and DC power supply combined into one module
- Redundant power supplies through power modules in a separate rack

Measurement and monitoring functions

All variables relevant to machine condition can be monitored with VIBROCONTROL 6000.

Measurement and monitoring functions are individually selected. The Safety Monitoring module continuously acquires the relevant measurements, forms the monitored parameter, compares it with predefined limit values and, if necessary, activates alarms.

Standard measurement parameters:

- Absolute casing vibration, with or without bearing condition measurement
- Relative shaft vibration
- Relative axial shaft position
- Relative shaft expansion
- Absolute casing expansion
- Speed, zero-speed
- Any process values, e.g. temperature, pressure, and others

Combination functions with dedicated modules:

- Unbalance monitoring
- Alignment monitoring
- Binary-signal activated Trip override and Trip multiplier functions
- Rod-drop monitoring at reciprocating compressors

Standard 19" rack format

VIBROCONTROL 6000 is always optimally adapted to the monitoring task. All typical monitoring tasks for machine protection can be fulfilled. The 19" Module Housing (3HE) is suitable for installation in cabinets with a depth of 400 mm.

Self-sufficient monitoring modules with own OK relay

All monitoring modules with up to 12 channels operate self-sufficiently and independently. All required functions for monitoring are locally available in the module. Extensive self-monitoring with control of a local OK relay is realised in each module.

Application-specific monitoring modules

The application-specific design concept of the monitoring modules gives them virtual "plug 'n play" capabilities, minimises the amount of time for setting up and gets the installed system up and running as fast as possible to shorten the time to win ROI.

Fast reaction time monitoring

For special applications a minimum reaction time of 10 ms is possible. This reaction time extends to the relays for alarming and the current and voltage output signals to downstream electronics as well.



Detection of signal saturation, sensor-OK monitoring and over voltage protection

A detector at each input channel prevents sudden rising input signals, sensor or cable faults from activating an alarm. Any faulty input signal registers an over-regulation. Programmable input ranges (OK windows) allow the system to be adapted to practically all commercially available sensors.

Power supply monitoring and redundancy

The AC and DC power supply are combined into a standard power supply module. To increase the availability of the system, VIBROCONTROL 6000 can be equipped with real redundant power supplies.

Differential inputs

With vibration measurements disturbance signals can often have a significant effect on the desired signal information. All input channels of VIBROCONTROL 6000 are therefore laid out as differential inputs. Thus synchronous disturbances are effectively suppressed as equalisation currents or cable noise.

Central building elements and their functions



RC-600 19" Module housing

Measurement and monitoring

The Module Housing is available in standard 19" design with a depth of 325 mm.

Individual combinations of monitoring modules allow optimum adaptation to the exact extent of the required monitoring application.

The system components consist of a 19" rack, Interface module, Safety Monitor modules and Power Supply module.

Construction

1 slot for the Computer Interface
4 slots for Safety Monitor modules and 1 or 2 Power Supply modules.

to configure:

up to 36 channels per rack with an internal PS-610/0 Power Supply module,

up to 24 channels per rack with two internal PS-610/0 Power Supply modules,
or
up to 48 channels per rack with an external Power Supply module.

Dimensions: 133 x 483 x 325 mm
(H x W x D)

Weight: approx. 5 kg

RC-610 19" Module Housing

External Power Supply

In 19" design and a depth of 235 mm, this rack is available for external redundant power supplies for one or more RC-6000 Module Housings.

Construction

6 slots for PS-610/1 Power Supply modules.



Measurement and Monitoring module and its functions

SM-610 Safety Monitoring module

Characteristics

- DSP-based signal processing
- up to 12 input channels (AC/DC)
- up to 12 output channels
- Sensor power
- 10 ms reaction time
- independently-operating measurement and monitoring
- local logbook

Inputs

6 input slots for

- 1-channel sensor interfaces
- 2-channel sensor interfaces
- 3-channel binary interfaces

Outputs

12 buffer signals at sub-D plug
6 output slots for

- 2-channel relay modules
- 2-channel DC-out modules

Displays:

- 3 LED monitoring status (Alert, Danger, relay latching)
- 1 LED local OK relay
- 4 LED system status (OK, TM, TO, Aux.)
- binary in/out from COM-module
- trigger in/out
- 12 LED sensor status (OK)

Dimensions: 100 x 129 x 295 mm
(W x H x D)

Module variation options:

Application-specific variations of the standard SM-610 module are available to achieve optimum adaptation of the monitoring system to the application.

VIBROCONTROL 6000 achieves maximum flexibility by the individual assignment of each SM-610 to the measurement and monitoring functions.

PS-610 Power Supply module

The PS-610 Power Supply module provides all modules installed in a rack, and all connected sensors, with the necessary power.

The following electrical power types can be used:

- AC voltage (90...265 V (45...65 Hz) and
- DC voltage (18...63 V)

The maximum power consumption is approx. 126 W.



You select the exact solution to your measurement and monitoring task from the standard or application-specific SM-610 modules. This achieves virtual 'plug 'n play' status for the system, with only minor changes to the module configuration.

The following variants are available:

PS-610/1 for installation in a RC-610 external rack (incl. connector set)
PS-610/0 for installation into the RC-600 measurement and monitoring rack (incl. complementary blind panel, length adapter, connecting set)





CI-610 Interface module

The CI-610 Interface module is equipped with an RS-232 serial interface.

Extent of functions:

- Display interface
- OPC for setup
- Parameter editing
- Local configuration
- Local firmware download

Hardware functions:

- Reset (binary inputs)
- Reset (button)
- Trip multiply
- Trip override
- OK relay
- Key-switch (operate/service)
- “Run” LED for operating condition

CI-615 Communication module

The CI-615 Communication module has a LAN (Ethernet TCP/IP) connection and two serial interfaces (RS-232 and 485) for Modbus communication.

Extent of functions:

- Display interface
- OPC with RC-600 rack and SM modules
- Single / dual Modbus RTU
- Parameter editing
- Local configuration
- Local firmware download
- Data export
- Data import
- Setup and service function
- Time synchronisation

Hardware functions:

- Reset (binary input)
- Reset (button)
- Trip multiply
- Trip override
- OK relay
- Key-switch (operate/service)
- “Run” LED for operating condition

VC-6000™ - Connectivity and Communication

Integration with process control systems

With its multi-faceted digital interfaces (incl. RS-232, -485 and 100 Mbit Ethernet) VIBROCONTROL 6000 allows comprehensive plant-wide system integration. For communication, OPC (OLE for process control) as well as Modbus RTU protocol (single/dual-Modbus) is also available. Measured data and alarm data from VIBROCONTROL 6000 are therefore available for connection to a plant-wide process control computer.

Safety and protective monitoring with VIBROCONTROL 6000

- Prevents dangerous machine operating conditions
- Protects personnel, the environment and plant against danger and damage
- Immediately identifies sudden and critical deviations from normal condition by high-speed acquisition of the relevant condition variables (execution of continuous measurement tasks and comparison of measurements with absolute limit values)
- Initiates the necessary measures to assure the safety of the process machine (typically initiate a shut-down)
- Maintains the safe status as long as there is no alternative instruction

- Is able to speed up bringing the process machine back to normal operation
- Operates reliably at all times through the use of an extensive strategy of incipient fault recognition and handling in the monitoring system
- Prevents false and unnecessary action

Communication options of VIBROCONTROL 6000

- LAN interface TCP/IP Ethernet
- Serial interface RS-232 and 485
- OPC client/server technology
- Modbus / dual-Modbus RTU

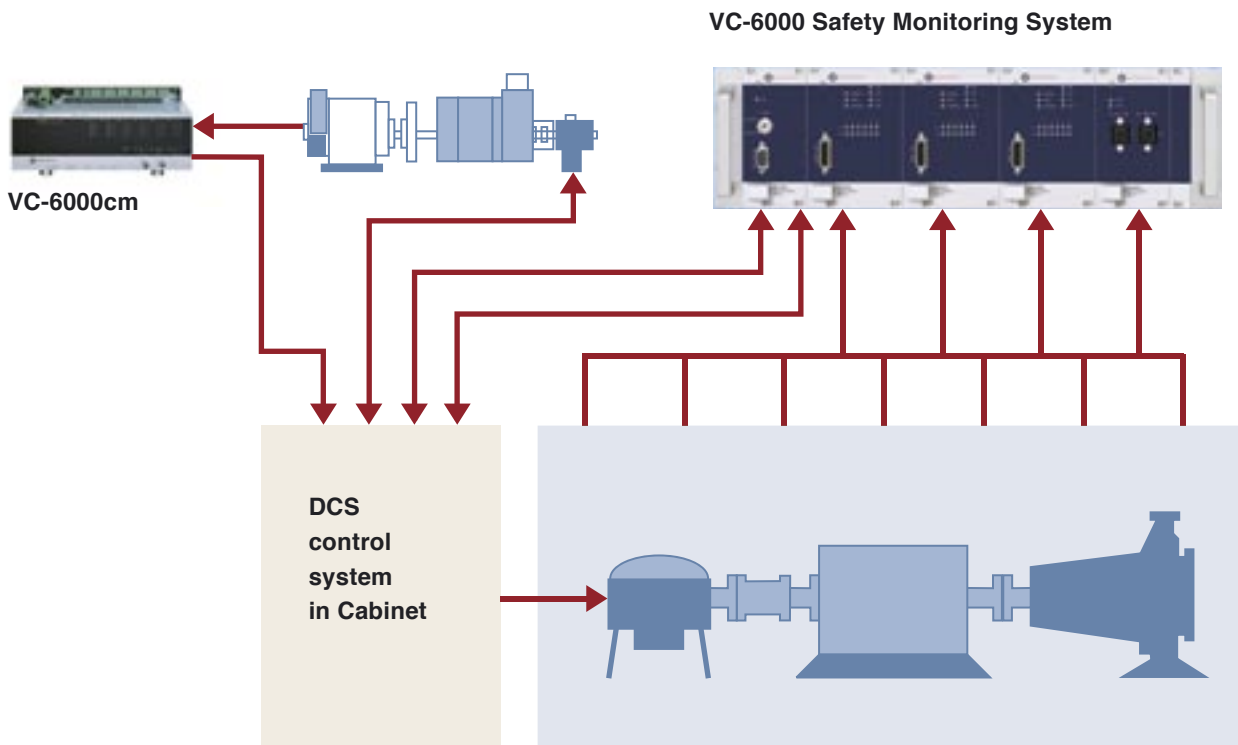

Brüel & Kjær Vibro A/S

Skodsborgvej 307 B
2850 Nærum
Denmark
Tel.: +45 77 41 25 00
Fax: +45 45 80 29 37
E-mail: info@bkvibro.com
www.bkvibro.com

Brüel & Kjær Vibro GmbH

Leydheckerstrasse 10
64293 Darmstadt
Germany
Tel.: +49 (0) 6151 428 1100
Fax: +49 6151 428 1200
E-mail: info@bkvibro.de
www.bkvibro.de