

Technical Specification

VIBROCONTROL 6000 Compact monitor



Applications

- Continuous safety monitoring for machines of all types
- Continuous data acquisition of vibration data and other measurement variables



Measuring and monitoring absolute casing vibration
Monitoring and assessment of machines according to DIN ISO 10816



Measuring and monitoring relative shaft vibration
Monitoring and assessment of machines according to DIN ISO 7919



Measuring and monitoring rolling-element bearing condition
Measuring and monitoring sm@rt value fault symptoms

Measuring and monitoring
Measuring and

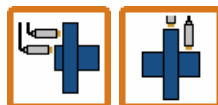

axial shaft position
monitoring radial shaft position

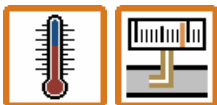

Measuring and monitoring temperature and process values

Further applications are under preparation.



Characteristics

- An instrument configuration of the VIBROCONTROL 6000 Compact monitor may consist of 1 to 3 input modules respective 1 to 6 channels for measuring and monitoring tasks
- Through flexible adaptation all the typical monitoring and machine protection requirements can be met
- sm@rt value monitoring using a measurement method specifically for individual fault symptoms of machines and machine components
- Digital signal processing (DSP) allows versatile and high processing speed together with high reliability, using fewer components
- Flexible monitoring function with wide-ranging performance; reaction time of only 5 ms is possible for special applications
- Potential-free outputs for alarming and signals to peripheral electronics; selectively relays can be controlled via voting logic
- Galvanically isolated measurement outputs as analogue current or voltage signals, updating of the output signal is extremely fast and is on the limits of technical possibility
- A high level of system dependability through complete self-monitoring with a central OK relay.
- Available with built-in power pack for AC or DC power.
- A connection is provided for an independent, redundant power supply.
- User terminal for local operation and display including English, German and French language support
- OPC interface for optional connection to a Windows PC (Process visualization, data export, data storage or plant-wide system integration).
- Protective housing for enclosing in an industrial environment can be supplied as an optional accessory



Contents of this Technical Specification*

- Machine monitoring with the VIBROCONTROL 6000 Compact monitor 4
 - Monitoring tasks and measurement variables 5
 - Inputs for sensors and signals 8
 - Sensor power and signal conditioning 8
 - Monitoring function 9
 - Analogue signal output 9
 - Digital Communication 9

- The Basic configurations for the VIBROCONTROL 6000 Compact monitor 10
 - Overview 10
 - The classic vibration monitor with vibration velocity sensor 11
 - Vibration measurement for output to peripheral control systems 12
 - The modern monitoring system with acceleration sensor 13
 - Monitoring of rolling-element bearing condition and casing vibration 15
 - The monitoring system for vibration, rolling-element bearing condition and process values 17
 - The correct solution for monitoring relative shaft vibration 19
 - Monitoring of axial position 20
 - Works default settings 22
 - Parameters & setting ranges for measurements and monitoring 24

- Hardware of the VIBROCONTROL 6000 Compact monitor 26
 - The Basic module 26
 - The connection modules 27

- Optional accessories 34
 - VIBROCONTROL 6000 Compact monitor User terminal 34
 - Protective housing for installing the VIBROCONTROL 6000 Compact monitor 35
 - in an industrial environment 35
 - Installation accessoires 36
 - Digital Communication 36
 - Sensors 37

* The technical specification is not intended to replace the product handbook. All important information for commissioning, operation and the technical safety instructions should be taken from the product handbook and the individual instrument’s documentation.

The instrument documentation is part of the standard delivery extent of a VIBROCONTROL 6000 compact monitor.



Machine monitoring with the VIBROCONTROL 6000 compact monitor

The VIBROCONTROL 6000 Compact monitor is designed mainly for continuous machine monitoring. It offers optimum and cost-effective monitoring to guarantee comprehensive machine protection with early fault detection.

The installation of a VIBROCONTROL 6000 Compact monitor consists of sensors, with their installation accessories, (also intrinsically-safe if required) and one or more VIBROCONTROL 6000 Compact monitor with user-specific configuration.

Why safety monitoring?

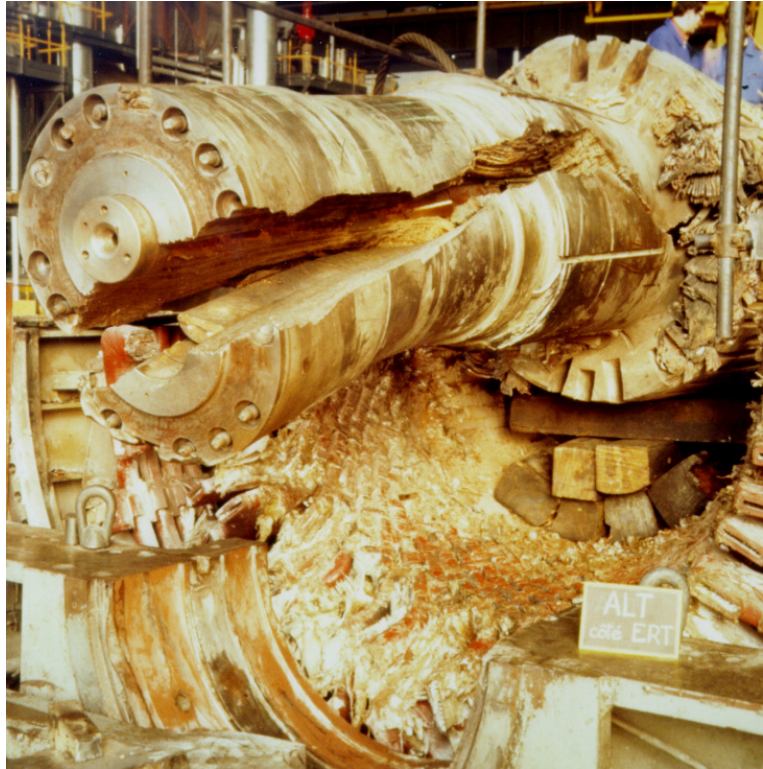

What is safety monitoring ?

Safety monitoring provides immediate recognition of, and reaction to, changes in machine condition that may constitute a danger to personnel, machines and the environment.

For safety monitoring, permanently-installed sensors, continuous measurement of vibration values and constant comparison of these values with predefined limit values are absolutely required. During daily operation the system provides warnings when vibration and other measurement variables deviate from their permissible levels. In a case where the measurements increase to critical levels, a shutdown of the machine can be initiated. To pass the measurements on to peripheral electronics galvanically isolated analogue outputs are available.







The VIBROCONTROL 6000 Compact monitor meets all the essential requirements of API 670 – the definitive standard for safety monitoring of machines, used in particular in power stations and petrochemical plants.













Monitoring tasks and measurement variables

The VIBROCONTROL 6000 Compact monitor is suitable for a number of applications. The correct measurement process must always be effected to correspond to the monitoring task. Thus it is self-explanatory that various applications must be combined into one instrument, e.g. monitoring of vibration severity according to DIN ISO10816 and monitoring rolling-element bearing condition.







Currently the following measurement and monitoring tasks can be carried out:

Monitoring task	Measurement type	
	Absolute casing vibration according to DIN ISO 10816	 RMS value of vibration velocity
Application Vibration monitoring according to DIN ISO 10816 serves for general purpose monitoring of a machine, where the dynamic forces on the rotor (e.g. from unbalance and deflection) are assessed as important symptoms for possible faults. As a rule rolling-element bearing damage cannot be identified by this measurement.		
	Rolling-element bearing condition	 Bearing condition unit
Application Monitoring of rolling-element bearing condition is a sensible supplement to monitoring according to DIN ISO 10816. The BCU measurement method is suitable for monitoring the condition of rolling-element bearings in standard and high-speed machines.		
	Rolling-element bearing condition	 Bearing condition bandpass (RMS value of vibration acceleration)
Application Monitoring of vibration acceleration serves for general purpose monitoring of a machine, where broad-band, structure-excited forces (e.g. from impact or stochastic excitation) are assessed as important symptoms for possible faults. This measurement method is especially suitable for the detection of rolling-element bearing damage in machines of all types, i.e. slow-, high-speed and standard machines.		
	Relative shaft vibration according to DIN ISO 7919	 S_{max} (Maximum excursion of the kinetic orbit)
Application Monitoring of the relative shaft vibration according to DIN ISO 7919 serves for monitoring of journal-bearing machines, where the vibration of the shaft relative to the housing (e.g. from unbalance or deflection) is mainly assessed for symptoms of possible faults.		



Monitoring task		Measurement type	
	Axial shaft position	 	Quasi-static displacement measurement relative to a reference point
	<p>Application This is the most important monitoring task in turbo-machines and machines with axial journal bearings. Faulty loading of the machine can lead to machine destruction in milliseconds due to overloading of the thrust bearing. Early identification of a limit violation that may indicate a worn or damaged thrust bearing can prevent contact between rotating and stationary parts and seizing of the rotor.</p>		
	Process values and temperature	 	Quasi-static measurement types
	<p>Application Monitoring of motor/bearing temperature and other important process values often permits early identification of faults and disturbances in the machine. In general process values are also very helpful in the assessment of machine vibrations, which many times are based on high vibration values only with unfavourable machine operating conditions.</p>		
	sm@rt value – Fault symptoms at machine components		Measurement types specific to fault symptoms
	<p>Application In general machine faults cannot be clearly identified using a standard monitoring procedure according to DIN ISO 10816 resp. DIN ISO 7919. High vibration values alone cannot be used to reach an adequate conclusion about the actual cause of the fault. Conversely each machine component exhibits specific fault symptoms that can be used for early fault identification. With sm@rt technology * a measurement method is used that specifically targets the individual fault symptoms of machines and machine components. This allows conspicuous machine components to be identified and the danger potential of the fault to be assessed already during operation. The necessary corrective action according to the fault and the potential danger can then be planned and executed at an early stage.</p> <p>Application examples Rotor unbalance, misalignment, gear wear, cavitation, degree of blade soiling, etc.</p> <p>sm@rt = Symptom monitoring at real time</p>		
On enquiry	User-defined monitoring tasks	   	Dynamic measurement types with user-defined signal filtering and signal detection
	<p>Application For user-defined task formulation</p>		
Further monitoring tasks are under preparation.			













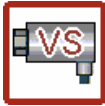
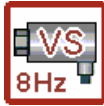

Monitoring task		Measurement type	
	Axial shaft position	 	Quasi-static displacement measurement relative to a reference point
	<p>Application This is the most important monitoring task in turbo-machines and machines with axial journal bearings. Faulty loading of the machine can lead to machine destruction in milliseconds due to overloading of the thrust bearing. Early identification of a limit violation that may indicate a worn or damaged thrust bearing can prevent contact between rotating and stationary parts and seizing of the rotor.</p>		
	Process values and temperature	 	Quasi-static measurement types
	<p>Application Monitoring of motor / bearing temperature and other important process values often permits early identification of faults and disturbances in the machine. In general process values are also very helpful in the assessment of machine vibrations, which many times are based on high vibration values only with unfavourable machine operating conditions.</p>		
	sm@rt value – Fault symptoms at machine components		Measurement types specific to fault symptoms
	<p>Application In general machine faults cannot be clearly identified using a standard monitoring procedure according to DIN ISO 10816 resp. DIN ISO 7919. High vibration values cannot be used to reach an adequate conclusion about the actual cause of the fault. Conversely each machine component exhibits specific damage symptoms that can be used for early fault identification. With sm@rt technology * a measurement method is used that specifically targets the individual fault symptoms of machines and machine components. This allows conspicuous machine components to be identified and the danger potential of the fault to be assessed already during operation. The necessary corrective action according to the fault and the potential danger can then be planned and executed at an early stage.</p> <p>Application examples Rotor unbalance, misalignment, gear wear, cavitation, degree of blade soiling, etc.</p> <p>sm@rt = Symptom monitoring at real time</p>		
Further monitoring tasks are under preparation.			

Inputs for sensors and signals

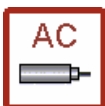
The VIBROCONTROL 6000 Compact monitor is prepared for specific sensors and input signals that correspond to the monitoring task. Thus various instrument configurations can be delivered to suit various monitoring tasks (see Basic configurations).

An instrument configuration of the VIBROCONTROL 6000 Compact monitor may consist of 1 to 3 input modules respective 1 to 6 channels for measuring and monitoring tasks. According to the task formulation and instrument configuration the following sensors and input signals can be connected:

Sensor type	Sensor types	
 Vibration acceleration sensors (accelerometers)	 	With 8 mA constant-current supply (CCS) or –24 VDC power
 Vibration velocity sensors	 	Series VS-06X or VS-07X
 Non-contacting displacement sensors		Series SD, IN oder DS
 User-defined quasi-static signals	 	DC current or DC voltage signals
 User-defined dynamic voltage signals		
 Under preparation: Phase reference sensors	 	Impulse voltage signals, e.g. for speed measurement
 Under preparation: Binary inputs for status signals		



Sensor power and signal conditioning

Each sensor connected to the VIBROCONTROL 6000 Compact monitor is handled in the optimum manner, because

- The power supply for connected sensor is specific to the type of sensor, e.g. constant-current 8 mA (CCS) or voltage –24 VDC / 30 mA
- The signal conditioning is dependent upon the connected sensor and the required measurement type; e.g. signal integration (0x, 1x, 2x), signal filtering (low-pass, high-pass), frequency response linearization for VS sensors (8 Hz or 15 Hz)

Monitoring function

The VIBROCONTROL 6000 Compact monitor is conceived for machine monitoring. For this purpose a measurement type is monitored for limit violation and events that occur are signalled to peripheral equipment by relay outputs.

  	<p>Monitoring with reference to absolute limit values typically 2 alarm limits (Alert & Danger alarm) for each measurement type, as per case further alarm limits Limit values can be set to over- or under-violation Limit values and time delays infinitely adjustable within range Trip-multiplier function</p> <p>Monitoring logic option Selectively either AND, OR or “2-of-3” voting logic is possible</p> <p>Relay output For alarming and signalling of events to peripheral equipment</p>
---	--

Analogue signal output

The VIBROCONTROL 6000 Compact monitor can output the continuously acquired measurement value as an analogue signal. The DC output signals can be executed through *galvanically isolated* outputs to peripheral equipment as current or voltage signals.

	<p>Analogue DC outputs e.g. with standard 4-20 mA or 0-10 V signals The output signal is individually adjustable (linear, non-linear or with individually zoomed regions).</p>
---	---

Digital Communication







The VIBROCONTROL 6000 Compact monitor can also export the continuously acquired measurement value as digital data. An OPC interface which can be optionally integrated in a TCP/IP Ethernet network is available. Thus the VIBROCONTROL 6000 Compact monitor is a data source which makes your measured data and status information available to a VIBROCONTROL 6000 Compact monitor OPC server.

	<p>Digital Communication using OPC (OPC = OLE for process control) The VIBROCONTROL 6000 Compact monitor can communicate with any arbitrary PC in which the SIMS OPC Server Software has already been installed and taken into operation. The SIMS OPC server itself is an open interface, making data available to further systems for storage or visualization (e.g. to xms software with process visualization).</p>
---	---



The Basic configurations for the VIBROCONTROL 6000 Compact monitor

Overview

Monitoring task	No. of channels	Sensor type	Order code		Page
			AC power	DC power	
Casing vibration according to DIN ISO 10816 	1x vibration	AS-CCS	CV-101-1-AC	CV-101-1-DC	11
			CV-111-1-AC	CV-111-1-DC	12
		AS-24V	CV-112-1-AC	CV-112-1-DC	13
	2x vibration	VS-8HZ	CV-114-1-AC	CV-114-1-DC	10
		AS-CCS	CV-111-2-AC	CV-111-2-DC	12
		AS-24V	CV-112-2-AC	CV-112-2-DC	13
Bearing condition BCU and casing vibration 	2x BCU and vibration	VS-8HZ	CV-114-2-AC	CV-114-2-DC	10
		AS-CCS	BC-121-2-AC	BC-121-2-DC	14
		AS-24V	BC-122-2-AC	BC-122-2-AC	14
Bearing condition BC-BP and casing vibration 	2x BC-BP and vibration	AS-CCS	BC-221-2-AC	BC-221-2-DC	15
		AS-24V	BC-222-2-AC	BC-222-2-AC	15
Bearing condition BC-BP, casing vibration and process value 	2x BC-BP and vibration	AS-CCS	BC-221-2 / UD-121-2-AC	BC-221-2 / UD-121-2-DC	16
	plus	und			
	2x process value	4-20mA			
Relative shaft vibration according to DIN ISO 7919 	2x vibration	DS	RV-117-2-AC	RV-117-2-DC	18
Axial shaft position 	1x static movement	DS	AP-117-1-AC	AP-117-1-DC	19
	3x static movement	DS	AP-327-3-AC	AP-327-3-DC	20



The classic vibration monitor with vibration velocity sensor

For general purpose monitoring of machines, monitoring the RMS value of vibration velocity has been proven. This value is best acquired using vibration velocity sensors for optimum reliability and safety against interference.

Traditionally a monitoring function is performed with 2 limit values and corresponding *potential-free* relay signals. In the case of slow-running machines a *built-in frequency linearization* takes care of the necessary adaptation.

Monitoring task 	1-channel vibration		2-channel vibration	
Order code	CV-114-1-AC	CV-114-1-DC	CV-114-2-AC	CV-114-2-DC
Power supply	90...264 VAC	18...75 VDC	90...264 VAC	18...75 VDC
Inputs No. of vibration channels Sensor connections Sensor power Sensor OK monitoring	1 1x velocity sensor e.g. VS-068, VS-069* not required yes		2 2x velocity sensor e.g. VS-068, VS-069* not required yes	
Absolute casing vibration Measurement type Signal filtering Analogue signal output Monitoring Signalling Relay control	each sensor: 1x RMS value of vibration velocity in [mm/s] 10 Hz – 1 kHz (2 Hz – 1 kHz) each sensor: 1x 4-20 mA or 0-20 mA or 2-10 V or 0-10 V each sensor: 1x Alert alarm and 1x Danger alarm each sensor: 1x Alert relay and 1x Danger relay strict channel independence			
Standard delivery extent Other Available accessories Works default settings Customer-defined settings	VIBROCONTROL 6000 Compact monitor including all necessary connection modules and connector set AC-4500 but excluding accessories (User terminal, sensors, etc.) see page 33ff see page 22f on enquiry (dedicated form sheet CV-114-1-X resp. CV-114-2-X)			
* Connections for VS-077 / VS-079 on enquiry				



Vibration measurement for output to peripheral control systems

Vibration measurement is still a measurement task for the specialist, and the signal preparation and measurement value processing require special care and some expense.

Normally the standards-conforming, assessed vibration signals are made available through *potential-free* analogue outputs for peripheral equipment.

<p>Monitoring task</p>	<p>1-channel vibration</p>	
Order code	CV-101-1-AC	CV-101-1-DC
Power supply	90...264 VAC	18...75 VDC
<p>Inputs No. of vibration channels Sensor connections Sensor power Sensor OK monitoring</p> <p>Absolute casing vibration Measurement type Signal filtering Analogue signal output</p>	<p>1 1x accelerometer, e.g. AS-062, 8325 constant-current (CCS), 8 mA yes</p> <p>1x RMS value of vibration velocity in [mm/s] 10 Hz – 1 kHz (2 Hz – 1 kHz) 1x 4-20 mA or 0-20 mA or 2-10 V or 0-10 V</p>	
<p>Standard delivery extent</p> <p>Other Available accessories Works default settings Customer-defined settings</p>	<p>VIBROCONTROL 6000 Compact monitor including all necessary connection modules and connector set AC-4500 but excluding accessories (User terminal, sensors, etc.)</p> <p>see page 33ff see page 22f on enquiry (dedicated form sheet CV-101-1-X)</p>	
<p>* Connection of other sensors on enquiry</p>		



The modern monitoring system with acceleration sensor

Modern acceleration sensors may also be used for monitoring of machines according to standards. In this case the desired measurement type is assessed by suitable conditioning of the signal. Limit value monitoring and alarm relay signalling are carried out in the customary manner. Acceleration sensors with CCS or with -24V power requirements can be used.

For CCS sensors:



Monitoring task 	1-channel vibration		2-channel vibration	
Order code	CV-111-1-AC	CV-111-1-DC	CV-111-2-AC	CV-111-2-DC
Power supply	90...264 VAC	18...75 VDC	90...264 VAC	18...75 VDC
Inputs No. of vibration channels Sensor connections Sensor power Sensor OK monitoring	1 1x accelerometer, e.g. AS-062 constant-current (CCS), 8 mA yes		2 2x accelerometer, e.g. AS-062 constant-current (CCS), 8 mA yes	
Absolute casing vibration Measurement type Signal filtering Analogue signal output Monitoring Signalling Relay control	each sensor: 1x RMS value of vibration velocity in [mm/s] 10 Hz – 1 kHz (2 Hz – 1 kHz) each sensor: 1x 4-20 mA or 0-20 mA or 2-10 V or 0-10 V each sensor: 1x Alert alarm and 1x Danger alarm each sensor: 1x Alert relay and 1x Danger relay strict channel independence			
Standard delivery extent Other Available accessories Works default settings Customer-defined settings	VIBROCONTROL 6000 Compact monitor including all necessary connection modules and connector set AC-4500 but excluding accessories (User terminal, sensors, etc.) see page 33ff see page 22f on enquiry (dedicated form sheet CV-111-1-X resp. CV-111-2-X)			



For acceleration sensors with –24 V power requirement:

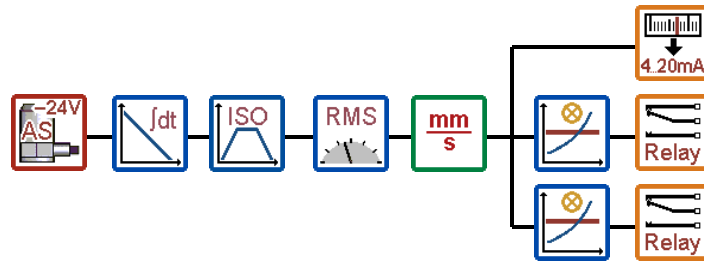

<p>Monitoring task</p> 	<p>1-channel vibration</p>		<p>2-channel vibration</p>	
<p>Order code</p>	<p>CV-112-1-AC</p>	<p>CV-112-1-DC</p>	<p>CV-112-2-AC</p>	<p>CV-112-2-DC</p>
<p>Power supply</p>	<p>90...264 VAC</p>	<p>18...75 VDC</p>	<p>90...264 VAC</p>	<p>18...75 VDC</p>
<p>Inputs No. of vibration channels Sensor connections Sensor power Sensor OK monitoring</p>	<p>1 1x accelerometer, e.g. AS-022 Voltage –24 VDC / max. 30 mA yes</p>		<p>2 2x accelerometer, e.g. AS-022 Voltage –24 VDC / max. 30 mA yes</p>	
<p>Absolute casing vibration Measurement type Signal filtering Analogue signal output Monitoring Signalling Relay control</p>	<p>each sensor: 1x RMS value of vibration velocity in [mm/s] 10 Hz – 1 kHz (2 Hz – 1 kHz) each sensor: 1x 4-20 mA or 0-20 mA or 2-10 V or 0-10 V each sensor: 1x Alert alarm and 1x Danger alarm each sensor: 1x Alert relay and 1x Danger relay strict channel independence</p>			
<p>Standard delivery extent</p> <p>Other Available accessories Works default settings Customer-defined settings</p>	<p>VIBROCONTROL 6000 Compact monitor including all necessary connection modules and connector set AC-4500 but excluding accessories (User terminal, sensors, etc.)</p> <p>see page 33ff see page 22f on enquiry (dedicated form sheet CV-112-1-X resp. CV-112-2-X)</p>			



Monitoring of rolling-element bearing condition and casing vibration

Rolling-element bearings are widely varied machine components. Because the peculiarities of rolling-element bearing damage are detectable only by suitable signal processes, monitoring of a rolling-element bearing condition parameter is done simultaneously with monitoring according to DIN / ISO. Such a monitoring system can e.g. be laid out for two sensors attached to two rolling-element bearing housings. Acceleration sensors with either CCS power or -24 V power requirements can be used.

Rolling-element bearing condition with classic BCU-measurement:

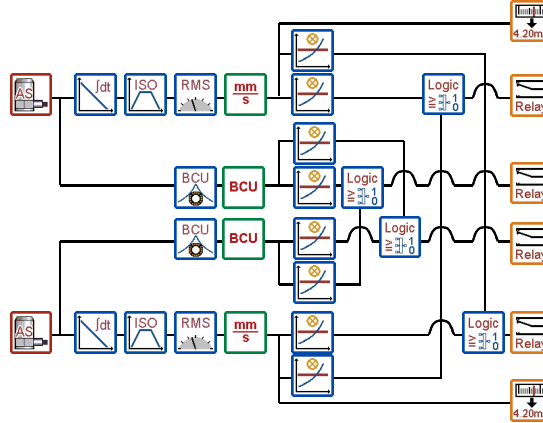

Monitoring task 	2-channel vibration and rolling-element bearing condition BCU			
Order code	BC-121-2-AC	BC-121-2-DC	BC-122-2-AC	BC-122-2-DC
Power supply	90...264 VAC		18...75 VDC	
Inputs No. of vibration channels Sensor connections Sensor power Sensor OK monitoring	2 2x accelerometer, e.g. AS-062 constant-current (CCS), 8 mA yes		2 2x accelerometer, e.g. AS-022 Voltage -24 VDC / max. 30 mA yes	
Absolute casing vibration Measurement type Signal filtering Analogue signal output Monitoring Signalling Relay control Bearing condition Measurement type Analogue signal output Monitoring Signalling Relay control	each sensor: 1x RMS value of vibration velocity in [mm/s] 10 Hz – 1 kHz (2 Hz – 1 kHz) each sensor: 1x 4-20 mA or 0-20 mA or 2-10 V or 0-10 V each sensor: 1x Alert alarm and 1x Danger alarm for both sensors: 1x Alert relay and 1x Danger relay OR linking both sensors for alert and danger separately each channel: 1x BCU (Bearcon condition unit) none each channel: 1x Alert alarm and 1x Danger alarm for both channels: 1x Alert relay and 1x Danger relay OR linking both sensors for alert and danger separately			
Standard delivery extent	VIBROCONTROL 6000 Compact monitor including all necessary connection modules and connector set AC-4500 but excluding accessories (User terminal, sensors, etc.)			
Other Available accessories Works default settings Customer-defined settings	see page 33ff see page 22f on enquiry (dedicated form sheet BC-121-2-X resp. BC-122-2-X)			



Rolling-element bearing condition by monitoring vibration acceleration:

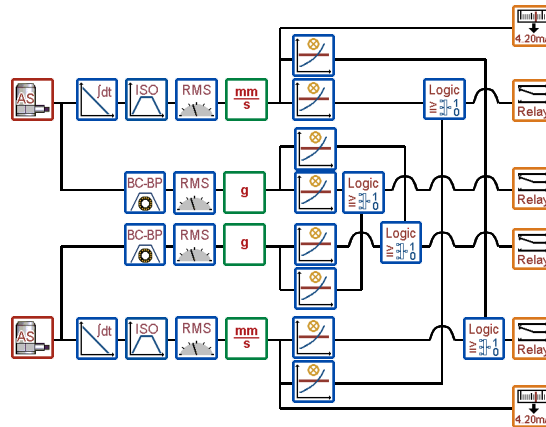

Monitoring task



2-channel vibration and rolling-element bearing condition BC-BP (Bearing Condition Bandpass)

Order code	BC-221-2-AC	BC-221-2-DC	BC-222-2-AC	BC-222-2-DC
Power supply	90...264 VAC	18...75 VDC	90...264 VAC	18...75 VDC
Inputs	No. of vibration channels: 2 Sensor connections: 2x accelerometer, e.g. AS-062 Sensor power: constant-current (CCS), 8 mA Sensor OK monitoring: yes		No. of vibration channels: 2 Sensor connections: 2x accelerometer, e.g. AS-022 Sensor power: Voltage -24 VDC / max. 30 mA Sensor OK monitoring: yes	
Absolute casing vibration	Measurement type: each sensor: 1x RMS value of vibration velocity in [mm/s] Signal filtering: 10 Hz – 1 kHz (2 Hz – 1 kHz) Analogue signal output: each sensor: 1x 4-20 mA or 0-20 mA or 2-10 V or 0-10 V Monitoring: each sensor: 1x Alert alarm and 1x Danger alarm Signalling: for both sensors: 1x Alert relay and 1x Danger relay Relay control: OR linking both sensors for alert and danger separately			
Bearing condition	Measurement type: each sensor: 1x RMS value of vibration acceleration in [g] Signal filtering: 1 kHz – 10 kHz Analogue signal output: none Monitoring: each sensor: 1x Alert alarm and 1x Danger alarm Signalling: for both sensors: 1x Alert relay and 1x Danger relay Relay control: OR linking both sensors for alert and danger separately			
Standard delivery extent	VIBROCONTROL 6000 Compact monitor including all necessary connection modules and connector set AC-4500 but excluding accessories (User terminal, sensors, etc.)			
Other	Available accessories: see page 33ff Works default settings: see page 22f Customer-defined settings: on enquiry (dedicated form sheet BC-221-2-X resp. BC-222-2-X)			

The monitoring system for vibration, rolling-element bearing condition and process values

Many machines need the process values and temperatures (motor windings and bearings) to be taken into consideration and to be monitored as a supplementary measure to the monitoring of vibration and rolling-element bearing condition.

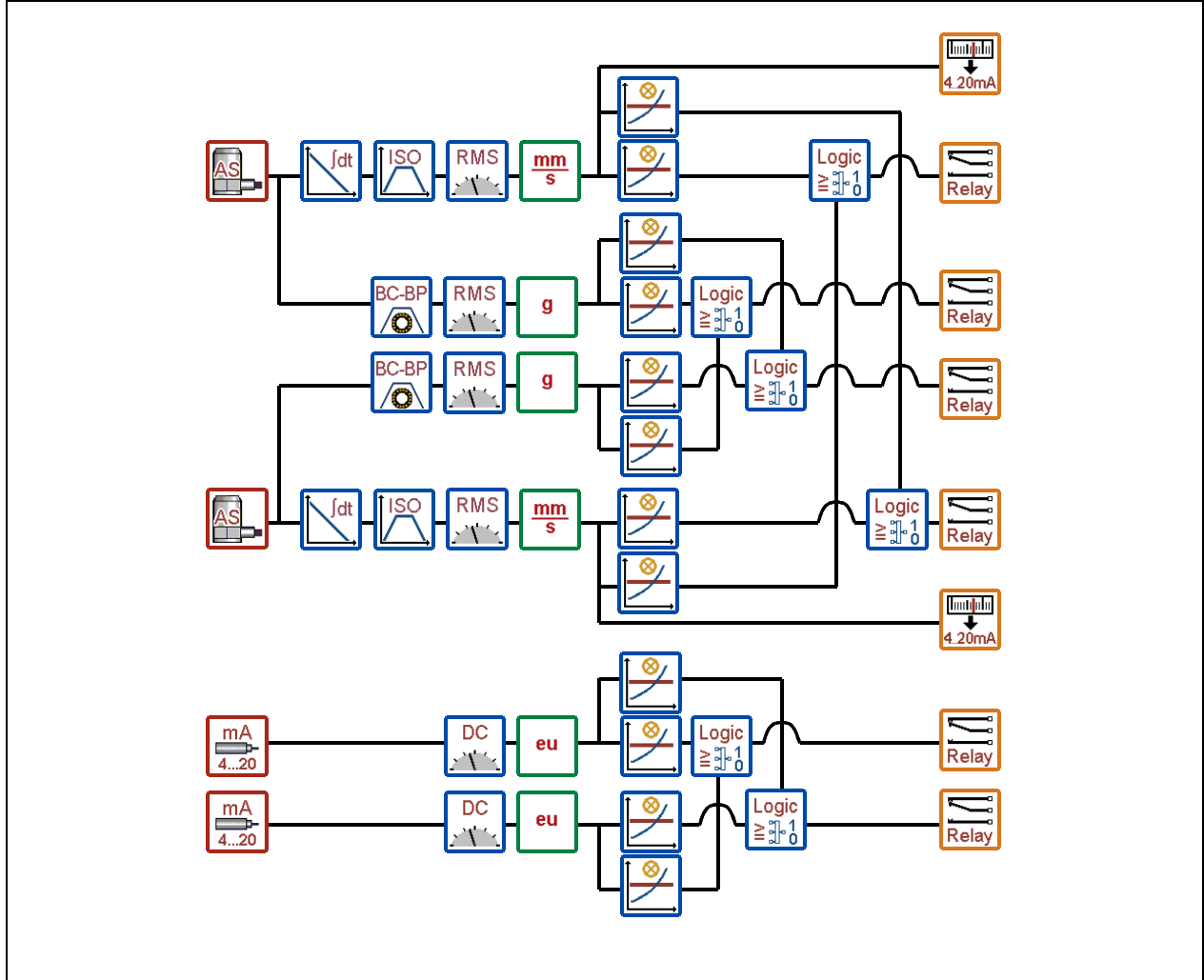



<p>Monitoring task</p> 	<p>2-channel vibration and rolling-element bearing condition BC-BP (Bearing Condition Bandpass) and 2-channels for process values 0/4-20mA</p>	
<p>Order code</p>	<p>BC-221-2 / UD-121-2-AC</p>	<p>BC-221-2 / UD-121-2-DC</p>
<p>Power supply</p>	<p>90...264 VAC</p>	<p>18...75 VDC</p>
<p>Inputs No. of vibration channels (AC channels) No. of process values (DC channels) Sensor connections Sensor power Sensor OK monitoring</p> <p>Absolute casing vibration Measurement type Signal filtering Analogue signal output Monitoring Signalling Relay control</p> <p>Bearing condition Measurement type Signal filtering Analogue signal output Monitoring Signalling Relay control</p> <p>Process values Measurement type Analogue signal output Monitoring Signalling Relay control</p>	<p>2</p> <p>2 2x accelerometer, e.g. AS-062</p> <p>2x process value inputs 4...20mA / 0...20mA each vibration channel: constant-current (CCS), 8mA yes</p> <p>each AC channel: 1x RMS value of vibration velocity in [mm/s] 10 Hz – 1 kHz (2 Hz – 1 kHz) each AC channel: 1x 4-20 mA or 0-20 mA or 2-10 V or 0-10 V each AC channel: 1x Alert alarm and 1x Danger alarm for both AC channels: 1x Alert relay and 1x Danger relay OR linking of both AC channels for alert and danger separately</p> <p>each AC channel: 1x RMS value of vibration acceleration in [g] 1 kHz – 10 kHz none each AC channel: 1x Alert alarm and 1x Danger alarm for both AC channels: 1x Alert relay and 1x Danger relay OR linking of both AC channels for alert and danger separately</p> <p>2x Process values in unit dimension [eu] none each DC channel: 1x Alert alarm and 1x Danger alarm for both DC channels: 1x Alert alarm relay and 1x Danger alarm relay OR linking of both DC channels for alert and danger separately</p>	
<p>Standard delivery extent</p> <p>Other Available accessories Works default settings Customer-defined settings</p>	<p>VIBROCONTROL 6000 Compact monitor including all necessary connection modules and connector set AC-4500 but excluding accessories (User terminal, sensors, etc.)</p> <p>see page 33ff see page 22f on enquiry (dedicated form sheet BC-221-2 / UD-121-2-X)</p>	



The correct solution for monitoring relative shaft vibration

At journal-bearing machines it is preferable that the relative shaft vibration be monitored. The necessary sensor arrangement consists of two eddy-current displacement sensors (X/Y) at each measurement point, mounted at 90° to one another. The measured signal from both sensors is monitored and assessed according to DIN ISO 7919.

Monitoring task 	2-channel relative shaft vibration for one X/Y-bearing plane	
Order code	RV-117-2-AC	RV-117-2-DC
Power supply	90...264 VAC	18...75 VDC
Inputs No. of vibration channels Sensor connections Sensor power Sensor OK monitoring Relative shaft vibration Measurement type Signal filtering Analogue signal output Monitoring Signalling	2 2x displacement sensors, e.g. SD-052 with OD-052 each sensor: -24 VDC / max. 30 mA yes 1x s_{max} in [μm] 10 Hz – 1 kHz (2 Hz – 1 kHz) 1x 4-20 mA or 0-20 mA or 2-10 V or 0-10 V 1x Alert alarm and 1x Danger alarm 1x Alert relay and 1x Danger relay	
Standard delivery extent Other Available accessories Works default settings Customer-defined settings	VIBROCONTROL 6000 Compact monitor including all necessary connection modules and connector set AC-4500 but excluding accessories (User terminal, sensors, etc.) see page 33ff see page 22f on enquiry (dedicated form sheet RV-117-2-X)	



Monitoring of axial position

Machines with journal bearings for the rotor can be totally destroyed in seconds when rotating parts of the rotor come into contact with stationary parts. This ever-present danger can be eliminated only when the axial position of the rotor relative to the stator is continuously and reliably monitored.



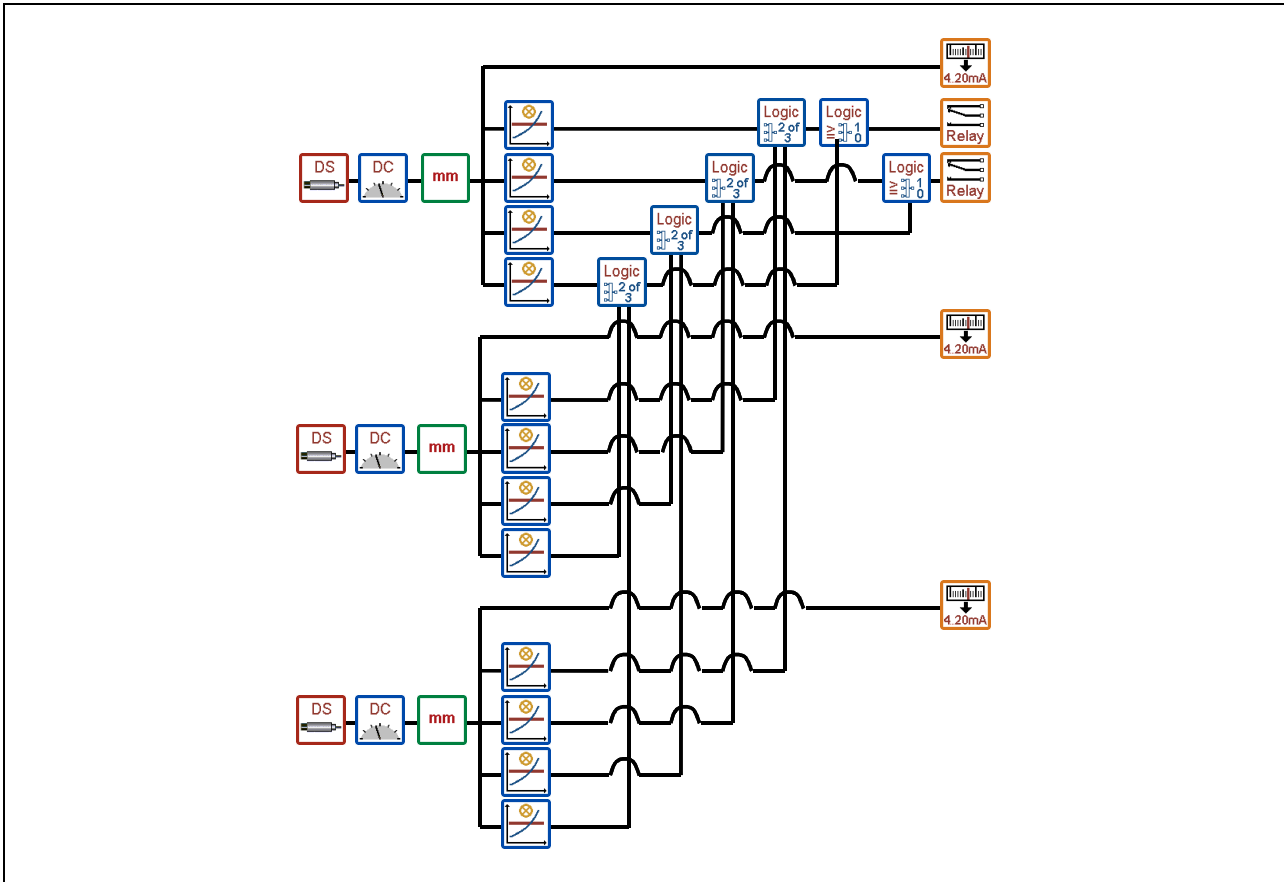

Monitoring task 	1-channel axial position	
Order code	AP-117-1-AC	AP-117-1-DC
Power supply	90...264 VAC	18...75 VDC
Inputs No. of DC channels Sensor connections Sensor power Sensor OK monitoring Axiale position Measurement type Analogue signal output Monitoring Signalling Relay control	1 1x displacement sensor, e.g. SD-052 with OD-052 each sensor: -24 VDC / max. 30 mA yes 1x DC (axial position) in [µm] 1x 4-20 mA or 0-20 mA or 2-10 V or 0-10 V Alert high, Alert low, Danger high and Danger low 1x Alert relay and 1x Danger relay OR linking of the high and low limits for Alert and Danger separately	
Standard delivery extent Other Available accessories Works default settings Customer-defined settings	VIBROCONTROL 6000 Compact monitor including all necessary connection modules and connector set AC-4500 but excluding accessories (User terminal, sensors, etc.) see page 33ff see page 22f on enquiry (dedicated form sheet AP-117-1-X)	





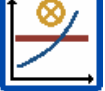

Monitoring task 	3-channel axial position with “2-of-3” voting logic	
Order code	AP-327-3-AC	AP-327-3-DC
Power supply	90...264 VAC	18...75 VDC
Inputs No. of DC channels Sensor connections Sensor power Sensor OK monitoring Axial position Measurement type Analogue signal output Monitoring Signalling Relay control	3 3x displacement sensor, e.g. SD-052 with OD-052 each sensor: -24 VDC / max. 30 mA yes each channel: 1x DC (axial position) in [µm] each channel: 1x 4-20 mA or 0-20 mA or 2-10 V or 0-10 V each channel: Alert high, Alert low, Danger high and Danger low 1x Alert relay and 1x Danger relay “2-of-3” linking of all channels for Alert and Danger separately including OR linking of high and low limits	
Standard delivery extent Other Available accessories Works default settings Customer-defined settings	VIBROCONTROL 6000 Compact monitor including all necessary connection modules and connector set AC-4500 but excluding accessories (User terminal, sensors, etc.) see page 33ff see page 22f on enquiry (dedicated form sheet AP-327-3-X)	

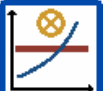

Works default settings

	
Absolute casing vibration according to DIN ISO 10816	
Input sensitivity	For accelerometers 100 mV/g For velocity sensors (e.g. VS-068/VS-069) 100 mV/mm/s
Measurement value	RMS value of vibration velocity in the frequency range from 10Hz and 1 kHz
Measurement range	0...20 mm/s rms with crest factor 5 (= 0...100 mm/s input range peak)
Averaging time	800 ms
	4...20mA corresponds to 0...20 mm/s RMS
	Alert alarm: limit value 7.1 mm/s; time delay 1 s Danger alarm: limit value 11 mm/s; time delay 1 s
	Alert relay: normally de-energized, non-latching Danger relay: normally de-energized, non-latching

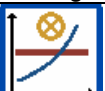
	
Rolling-element bearing condition BCU	
Input sensitivity	For accelerometers 100 mV/g
Measurement value	BCU
Measurement range	0...100 BCU
Averaging time	1 s
	Alert alarm: limit value 1 BCU; time delay 1 s Danger alarm: limit value 2 BCU; time delay 1 s
	Alert relay: normally de-energized, non-latching Danger relay: normally de-energized, non-latching

	
Rolling-element bearing condition BC-BP (bearing condition bandpass)	
Input sensitivity	For accelerometers 100 mV/g
Measurement value	RMS value of acceleration in the frequency range from 10Hz and 1 kHz
Measurement range	0...16 g RMS with crest factor 5 (= 0...80 g peak value)
Averaging time	800 ms
	Alert alarm: limit value 1 g; time delay 1 s Danger alarm: limit value 4 g; time delay 1 s
	Alert relay: normally de-energized, non-latching Danger relay: normally de-energized, non-latching











Relative shaft vibration according to DIN ISO 7919, s_{max}	
Input sensitivity	For displacement sensors 8 mV/ μ m
Measurement value	s_{max} in the frequency range from 10 Hz to 1 kHz
Measurement range	0...250 μ m
Peak detector	rise time 3 ms, decay time 300 ms
	4...20mA corresponds to 0... 250 μ m
	Alert alarm: limit value 50 μ m; time delay 1 s Danger alarm: limit value 70 μ m; time delay 1 s
	Alert relay: normally de-energized, non-latching Danger relay: normally de-energized, non-latching

Axial shaft position	
Input sensitivity	For displacement sensors 8 mV/ μ m
Measurement value	static movement (DC value) of axial shaft position
Measurement range	-1...+1 mm
Averaging time	1 s
	4...20mA corresponds to -1...+1 mm
	Alert alarm: limit value +/- 0,5 mm; time delay 1 s Danger alarm: limit value +/- 0,8 mm; time delay 1 s
	Alert relay: normally de-energized, non-latching Danger relay: normally de-energized, non-latching







Process value	
Input sensitivity	4...20 mA corresponds to 0...150 eu
Measurement value	Quasi-static process value (DC value)
Measurement range	0...150 eu
Averaging time	1 s
	Alert alarm: limit value 100 eu ; time delay 1 s Danger alarm: limit value 120 eu ; time delay 1 s
	Alert relay: normally-energized, non-latching Danger relay: normally de-energized, non-latching

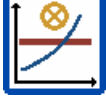

Parameters & setting ranges for measurements and monitoring

	Parameter	Settings
	Sensitivity Max. input signal Sensor OK latching	Typical 100 mV/mm/s or 75 mV/mm/s Setting range: 0.01...99999.99 mV/mm/s 10.00...100 [mm/s peak] (at 100 mV/mm/s) yes or no
	Sensitivity Max. input signal Sensor OK latching	Typical 100 mV/g or 10 mV/g Setting range: 0.01...99999.99 mV/g Integrated: 12.50...100.00 [mm/s peak] (at 100 mV/g) Not integrated: 1.25...80.00 [g peak] (at 100 mV/g) yes or no
	Sensitivity Max. input signal Sensor OK latching	Typical 8 mV/μm oder – 8 mV/μm Setting range: – 99999.99... + 99999.99 mV/μm 25.00...1000.00 μm peak (at 8 mV/μm) yes or no
	Monitoring task Measurement value Unit Averaging time Highpass frequency Lowpass frequency Full-scale measurement range	Absolute casing vibration according DIN ISO 10816 RMS value of vibration velocity; fixed setting [mm/s] or [ips] 100 ms; 200 ms; 400 ms; 800 ms... 51.2 s 10 Hz, 2 Hz or 1 Hz 1 kHz; fixed setting with crest factor 5: 2.50...20.00 [mm/s RMS] (at 100 mV/mm/s respective 100 mV/g)
	Monitoring task Measurement value Averaging time Multiplier Divider Full-scale measurement range	Bearing condition (BCU) Bearing condition unit; fixed setting 0.01 s...99.99 s; step size 0.01 s 1...1000; step size 1 1...1000; step size 1 10...200 BCU; step size 0.01 BCU (at 100 mV/g)
	Monitoring task Measurement value Frequency range Averaging time Full-scale measurement range	Bearing condition (bearing condition bandpass) RMS value of vibration acceleration in [g], fixed setting 1 kHz bis 10 kHz; fixed setting 25 ms; 50 ms; 100 ms; 200 ms...51,2 s fixed setting
	Monitoring task Measurement value Unit Rise time Decay time Highpass frequency Lowpass frequency Full-scale measurement range	Relative shaft vibration according DIN ISO 7919 Smax; fixed setting [μm]; fixed setting 1 ms...99 ms; step size 1 ms 0.1 s...9,9 s; step size 0.1 s 10 Hz, 2 Hz or 1 Hz 1 kHz; fixed setting 25...1000 μm; step size 0.01 μm (at 8 mV/μm)
	Monitoring task Measurement value Unit Averaging time Zero offset Measurement range	Axial shaft position Quasi-static displacement (DC-value) [μm] or [mils] 0.01 s...99.99 s; step size 0.01 s – 1250 μm respective –10 V (at – 8 mV/μm) Setting range: ± 0... ± 9999.99 μm, step size 0.01 μm ± 1000 μm (bei – 8 mV/μm) Setting range: ± 0... ± 99999.99 μm, Schrittweite 0.01 μm
	Monitoring task Signal type Unit Measurement range	Process value 4-20 mA, 0-20 mA, 2-10 V, 0-10 V, 0-5 V or user-defined in the range ± 30 mA / ± 15 V [eu]; fixed setting Starting value and end value in the range from – 99999.99 to + 99999,99; step size 0.01





	<p>DC-output Signal type</p> <p>Unit Output value range</p> <p>Non-linear output curve</p>	<p>e.g.: 4-20 mA signal corresponds to range 0 to 150 eu</p> <p>4-20 mA / 2-10 V or 0-20 mA / 0-10 V or 0-5 V or user-defined in the range of 0-20 mA or 0-10V fixed setting according the associated measurement</p> <p>Starting value and end value in the range from - 99999.99 to + 99999.99; step size 0.01 (e.g. monitoring according DIN ISO 10816: signal 4-20 mA corresponds to range 0...20 [mm/s])</p> <p>yes or no; if yes, one or two additional fixed points have to be defined inside the output value range in the format (measurement value / output level)</p>
	<p>Monitor (absolute) Limit type</p> <p>Unit Limit setpoint Hysteresis Time delay</p>	<p>High limit or low limit fixed setting according the associated measurement</p> <p>- 99999.99 ... + 99999.99; step size 0.01</p> <p>- 99999.99 ... + 99999.99; step size 0.01</p> <p>0.00 s ... 99.99 s; step size 0.01 s</p>
	<p>Logic</p>	<p>Fixed setting according selected signal path respective device configuration</p>
	<p>Relay Output Normal position Latching</p>	<p>Energized or de-energized yes or no</p>
	<p>Variable Filter Highpass frequency Lowpass frequency</p>	<p>1 Hz...16 kHz; step size 23% (1/3 octave) 1,25 Hz...20 kHz; step size 23% (1/3 octave) (steps: 1 / 1,25 / 1,6 / 2 / 3,15 / 4 / 5 / 6,3 / 8 / 10...)</p>
	<p>DC measurement Unit Averaging time Zero offset</p>	<p>[eu], [μm], [mm], [mils] or [°C] 0.01 s...99.99 s; step size 0.01 s - 9999.99 ... + 9999.99; step size 0.01</p>
	<p>Peak measurement Unit Rise time Decay time</p>	<p>[g], [m/s²], [mm/s], [ips], [μm], [mils] or [eu] 1 ms...99 ms; step size 1 ms 0.1 s...9,9 s; step size 0.1 s</p>
	<p>RMS measurement Unit Averaging time</p>	<p>[g], [m/s²], [mm/s], [ips], [μm], [mils] or [eu] 25 ms; 50 ms; 100 ms; 200 ms...51.2 s</p>



Hardware of the VIBROCONTROL 6000 Compact monitor

The Basic module

Each VIBROCONTROL 6000 Compact monitor contains a central hardware element group which integrates the main system functions.

Basic module type	Basic module AC for use with AC voltage power	Basic module DC for use with DC voltage power
Power supply	 90...264 V / 50...60 Hz	 18...75 VDC
Inputs Outputs and supplementary modules Signal processor Memory Measurement function Monitoring function Self-monitoring Operational status display Digital Interface Other connections	<ul style="list-style-type: none"> - 3 sockets for input modules - each according to module equipment 1 to 6 channels for measuring and monitoring purposes, - max. 3 channels for vibration sensors - maximum frequency range: DC...20kHz - 6 sockets for modules - each according to module equipment up to 12 output channels (analogue DC outputs or signalling relays) - Digital Signal Processor (DSP) - 16-bit Analogue-Digital-Converter (64kHz sampling rate per channel), for 6 independent signal paths / inputs - 16 Mbit Flash system memory (non-volatile), for Firmware and Logbook - Independent of instrument configuration (Hardware & Firmware) - All measuring ranges freely adjustable - Independent of instrument configuration (Hardware & Firmware) - Monitoring of power supply, system functions and sensor function, (cycle time 1 ms), event signalling through central OK relay with status LED - Through LED according to DIN19235: Signalling of alarm status, OK status and power supply status - Serial interface for Configuration and Service - Optional connection for digital communication - Connection for local User terminal - Connection for redundant external power supply - Connection for remote reset (binary input signal) 	
Mechanical equipment Dimensions Weight Ambient conditions	<p>Metal housing with IP20 protection class for mounting on a 35 mm rail</p> <p>311 mm x 170 mm x 113 mm (width x height x depth)</p> <p>approx. 2.5 kg (max. module configuration, excl. protective housing)</p> <p>Operating temperature range: -20...+70 °C Storage temperature range: -40...+85 °C respectively at 95%, non-condensing humidity</p>	



The connection modules

Input module for acceleration sensors

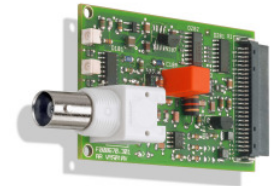

Characteristics

- Arranged for one acceleration sensor
- Acquires acceleration signals
- Provides power to the sensor
- Integrated sensor monitoring function
- Optional signal integration to vibration velocity



Application



Measuring and monitoring of absolute casing vibration



Measuring and monitoring of rolling-element bearing condition

Module type	A-TIM (Acceleration Transducer Interface Module)	
	A-TIM-CCS	A-TIM-24 V
Inputs Voltage range Impedance Frequency range Sensitivity	1 (Differential amplifier) -21,5...+2,5 V 200 kOhm DC...50 kHz adjustable	1 (Differential amplifier) -21,5...+2,5 V 200 kOhm DC...50 kHz adjustable
Buffered output Voltage range Gain Offset Output impedance Frequency range	1 (BNC socket) -21...+2 V 1 (± 2 %) < 15 mV min. 10 kOhm DC...50 kHz	1 (BNC socket) -21...+2 V 1 (± 2 %) < 15 mV min. 10 kOhm DC...50 kHz
Sensor power	Constant-current (CCS), 8mA	Voltage -24V DC / max. 30mA
Sensor monitoring Sensor-OK Input range OK (Over-range)	1x LED green 1x LED red	1x LED green 1x LED red
Other	1x analogue integration (programmable)	1x analogue integration (programmable)
Usable sensors	AS-062, ASA-062, 8325, 8326, 8327, 8331, 8332	AS-022, ASA-022, AS-030 or external charge amplifier, type 2661 & 2667
		



Input module for velocity sensors

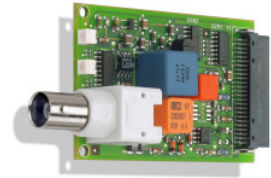



Characteristics

- Arranged for one vibration velocity sensor
- Acquires vibration velocity signals
- Integrated frequency response linearization
- Integrated sensor monitoring function

Application

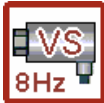

Measuring and monitoring absolute casing vibration

Module type	V-TIM (Velocity Transducer Interface Module)	
	V-TIM-8 HZ	V-TIM-15 HZ
Inputs	1 (Differential amplifier)	1 (Differential amplifier)
Voltage range	-21,5....+2,5 V	-21,5....+2,5 V
Impedance	27 kOhm	27 kOhm
Frequency range	DC...>20 kHz	DC...>20 kHz
Sensitivity	adjustable	adjustable
Buffered output	1 (BNC socket)	1 (BNC socket)
Voltage range	-21....+2 V	-21....+2 V
Gain	1 (± 2 %)	1 (± 2 %)
Offset	< 15 mV	< 15 mV
Output impedance	min. 10 kOhm	min. 10 kOhm
Frequency range	DC...>20 kHz	DC...>20 kHz
Sensor power	Sensor and cable OK monitoring	Sensor and cable OK monitoring
Sensor monitoring		
Sensor-OK	1x LED green	1x LED green
Input range OK (Over-range)	1x LED red	1x LED red
Other	Frequency response linearization	Frequency response linearization
Usable sensors	VS-068, VS-069, VS-168, VS-169, VS-288	VS-077, VS-078, VS-177, VS-277
		



Input module for displacement sensors

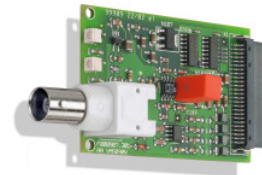

Characteristics

- Arranged for one non-contacting displacement sensor
- Acquires displacement and vibration signals
- Acquires phase-reference signals (impulse signals)
- Provides power to the sensor
- Integrated sensor monitoring function



Application

Measuring and monitoring relative shaft vibration
(2 Modules per measuring plane required)





Measuring and monitoring axial shaft position



Measuring and monitoring radial shaft position
(2 Modules per measuring plane required)



Measuring and monitoring speed (under preparation)

Module type	D-TIM (Displacement Transducer Interface Module)
Inputs	1 (Differential amplifier)
Voltage range	-21,5....+2,5 V
Impedance	200 kOhm
Frequency range	DC...50 kHz
Sensitivity	adjustable
Buffered output	1 (BNC socket)
Voltage range	-21....+2 V
Gain	1 (± 2 %)
Offset	< 15 mV
Output impedance	min. 10 kOhm
Frequency range	DC...>20 kHz
Sensor power	Voltage -24V DC / max. 30mA
Sensor monitoring	
Sensor-OK	1x LED green
Input range OK (Over-range)	1x LED red
Usable sensors	Displacement sensors of the series SD, IN and DS
	 For displacement and vibration measurement
	 As reference sensor (speed sensor)

Input module for current and voltage signals

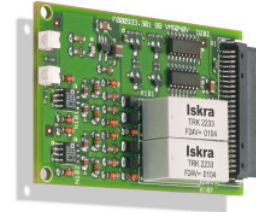

Characteristics

- 2 signal inputs
- Acquires quasi-static current and voltage signals
- Acquires dynamic voltage signals
- Acquires phase-reference signals (impulse signals)
- Integrated signal monitoring function

Application







Measuring and monitoring process values and quasi-static signals (current and voltage)



Measuring and monitoring dynamic voltage signals



Measuring and monitoring speed (under preparation)

Module type	GP-TIM (2-ch.) (General Purpose Transducer Interface Module)
Inputs Voltage range / Impedance Frequency range Current input range Current signal load Sensitivity	2 (Differential amplifiers) -15...+15 V / 200 kOhm DC...50 kHz -30...+30 mA 100 Ohm adjustable
Signal monitoring Input OK (Overload)	1x LED green per channel
Possible input signals	  <p>0/4...20mA current signals 0/2...10V voltage signals</p>   <p>User-defined voltage signals -15...+15V</p>  <p>Trigger signals -15...+15V</p>

Conditioning module for BCU (Bearing Condition Unit)

Characteristics

- 2 Signal inputs from adjacent input modules
- BCU signal processing
- Integrated signal monitoring function
- Only in combination with one or two A-TIM input modules*

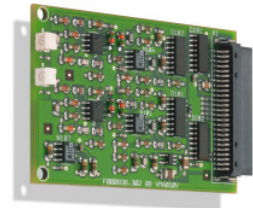

Application



Measuring and monitoring rolling-element bearing condition

Module type	BCU-CON (2-ch.); (BCU Conditioning Module)
Inputs	2 (from adjacent input modules)
Signal processing	
Signal filtering	15...60 kHz
Signal detection	Peak detector
Signal output	Instantaneous value of BCU
Signal monitoring	
Input range OK (Over-range)	1x LED red per channel

The BCU-CON module occupies the socket of one input module. Together with two A-SIM modules this automatically limits the number of channels of the VIBROCONTROL 6000 Compact monitor to 2 channels.



Relay output module

Characteristics

- 2 *potential-free* output relays

Application



Alarming and event signalling to peripheral equipment

Module type	Relay-Out (2-ch.)
No. of output relay	2, potential-free
Relay type	Change-over, mono-stable
Switching mode	Normally energised and normally de-energised (programmable)
Time delay	freely programmable (0,00...99,99 s)
Electrical data	
Nominal operating voltage	24...48 V DC
Minimum voltage	10 mV
Maximum current load	500 mA
Minimum current	10 μ A
Operating status display	1x LED green and 1x LED yellow/red per channel

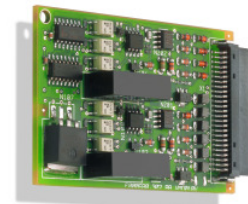

Output module for current and voltage signals



Characteristics

- 2 *galvanically isolated* DC outputs, *short-circuit proof*
- Output of current signals (e.g. 4...20mA)
- Output of voltage signals (e.g. 0...10V)
- Programmable for linear and non-linear output signal curve

Application

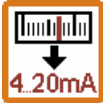

Preparation of measured values as analogue signals for peripheral equipment

Module type	DC-Out (2-ch.)
No. of DC outputs Reaction time	2, galvanically isolated, short-circuit proof 5 ms
Electrical data	
 Current output range Max. load	4-20 mA or 0-20 mA 500 Ohm
 Voltage output range Min. output load	0-10V or 2-10V or 0-5V 1 kOhm



Optional accessories

(not part of standard delivery)

VIBROCONTROL 6000 Compact monitor

User terminal



Order code	UT-100
Function	VIBROCONTROL 6000 Compact monitor local operation Display current measured value Display Logbook contents Change parameter settings (e.g. limit values)
Display	2-line display (2x 16 characters)
Language support	English, German and French
Operation	Sealed-foil front panel with 5 buttons
Operating temperature	-20 °C...+70 °C
Protection class	IP 20
Connection	D-Sub-socket at the front panel of the VIBROCONTROL 6000 Compact monitor
Delivered accessories	Fixed connecting cable, 2.5 m length Locking clip AC-4501 for DIN-rail mounting



Protective housing for installing the VIBROCONTROL 6000 Compact monitor in an industrial environment

Order code	AC-2100/55
	protective housing of sheet metal with window suitable for 1 piece VIBROCONTROL 6000 Compact monitor or for the installation of the network interface
Ambient conditions	Industrial environment, Non-Ex
Protection class	IP55
Size	400 mm x 200 mm x 155 mm
Empty weight	appr. 7 kg
Colour	RAL 7032

Order code	AC-2100/66
	protective housing of sheet metal suitable for 1 piece VIBROCONTROL 6000 Compact monitor or for the installation of the network interface
Ambient conditions	Industrial environment, Non-Ex
Protection class	IP66, Nema 4, 12 & 13
Size	400 mm x 200 mm x 125 mm
Empty weight	appr. 4.3 kg
Colour	RAL 7032



Installation accessories

Order code	
AC-2600	Component set for cable shielding for terminating and grounding of incoming sensor cable shields consisting of one common rail , clamps and spring-terminals <u>Application:</u> for installing the VIBROCONTROL 6000 Compact monitor in housings or cabinets without own shielding concept
AC-4500	Connector set for the VIBROCONTROL 6000 Compact monitor
AC-4501	Locking clip for the Compact monitor User terminal For mounting the User terminal on a 35 mm rail

Digital Communication

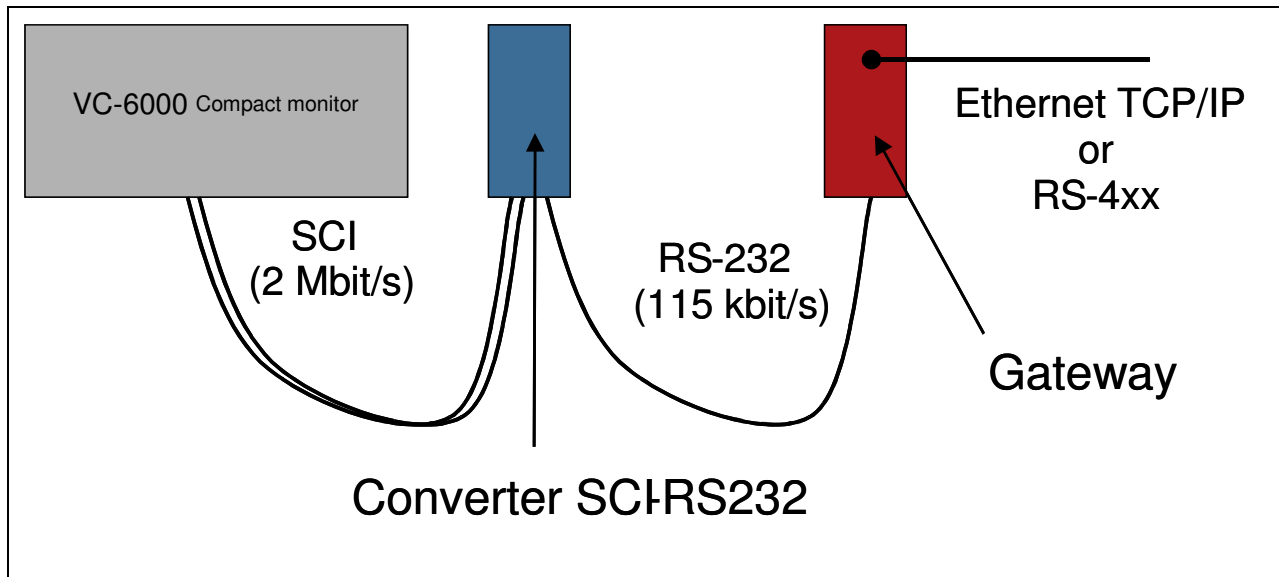

Order code	
AC-5003	Converter SCI-RS232 for DIN-rail mounting
AC-5004	2-Port Ethernet-Gateway for DIN-rail mounting
7131	OPC Data Access Server



Sensors

For detailed sensor information please consult our sensor catalogue

Accelerometers

Order code	
AS-022	100 mV/g, Power –24 VDC, up to 125°C 5 m connecting cable, Steel protective cable conduit option
AS-030	100 mV/g, Power –24 VDC, up to 125°C, Fast-on connectors
AS-062/050/0	CCS sensor, 100 mV/g, up to 125°C, 5 m connecting cable
AS-062/100/0	Sensor with 10 m connecting cable
AS-062/050/1	Sensor with 5 m connecting cable and steel protective cable conduit
AS-070/001	CCS sensor, 100 mV/g, up to 120°C, 10 m connecting cable
AS-070/002	CCS sensor, 100 mV/g, up to 120°C, 10 m connecting cable
AS-080/01	CCS sensor, 100 mV/g, up to 150°C, MIL-C-5015 2-pole
8325-A-0	CCS sensor, 100 mV/g, up to 125°C, MIL-C-5015 2-pole
8325-S-1-03-A-0100	CCS sensor, 100 mV/g, up to 125°C, 10 m connecting cable Other cable lengths on enquiry
8327-A-0	CCS sensor, 10 mV/g, up to 125°C, MIL-C-5015 2-pole
8327-S-1-03-A-0100	CCS sensor, 10 mV/g, up to 125°C, 10 m connecting cable Other cable lengths on enquiry
8331-A-0	CCS sensor, 100 mV/g, up to 125°C, MIL-C-5015 2-pole
8331-S-1-03-A-0100	CCS sensor, 100 mV/g, up to 125°C, 10 m connecting cable Other cable lengths on enquiry
8332-A-0	CCS sensor, 10 mV/g, up to 125°C, MIL-C-5015 2-pole
8332-S-1-03-A-0100	CCS sensor, 10 mV/g, up to 125°C, 10 m connecting cable Other cable lengths on enquiry
	For high-temperature sensors, charge-amplifiers and sensors for Ex areas (see sensor catalogue) Installation accessories and connecting cable (see sensor catalogue)

Vibration velocity sensors

Order code	
VS-068	100 mV/mm/s, horizontal measuring direction, 5 m connecting cable, steel protective cable conduit
VS-069	100 mV/mm/s, vertical measuring direction, 5 m connecting cable, steel protective cable conduit
VS-077	75 mV/mm/s, hor./vert. measuring direction, 5 m connecting cable, steel protective cable conduit
VS-079	75 mV/mm/s, hor./vert. measuring direction, 5 m connecting cable, steel protective cable conduit, up to 200°C
	Sensors for Ex areas, Installation accessories and connecting cable See catalogue VIBROSENSORS BV-P1001/3e

Displacement sensors

See catalogue VIBROSENSORS BV-P1001/3e

Brüel & Kjaer Vibro reserves the right to change specifications and accessories without notice.

The current version of this document is available at <http://www.bkvibro.de> or <http://www.bkvibro.com>